



[PREVIOUS](#)   
[MENU](#)

**NISSAN RE4F04A**

**INDEX**

**GO TO PAGE**

**Electrical Control and Parts.....Page 3**

**Trouble Shooting Diagnosis.....Page 6**

**Pressure Testing.....Page 14**

**Diagnosis Chart.....Page 16**

**Transaxle Teardown.....Page 19**

**Component Teardown.....Page 34**

**Valve Body.....Page 41**

**Clutch Packs.....Page 56**

**Final Drive.....Page 88**

**Transaxle Assembly.....Page 97**

**General Specifications.....Page 112**

**AUTOMATIC TRANSMISSION SERVICE GROUP**  
9200 S. Dadeland Blvd.  
Suite 720  
MIAMI FLORIDA 33156  
(305) 670-4161



# **INTRODUCTION NISSAN RE4F04A**

The NISSAN RE4F04A electronically-controlled automatic transaxle features a combination of electronic and mechanical systems to control forward gear shifting torque converter lock-up for quietness and economy and self diagnosis capability for simplifying trouble shooting procedures.

The electronic system controls the transaxle shifting in forward speeds and controls torque converter lock-up by means of solenoid actuated valves. These shift solenoids valves, when energized, acuate friction elements (clutches and band) to control shifting. The shift timing and lock-up events are regulated by the TCM in programmed logic and in response to input sensors and switches to produce optimum driveability..

**We thank NISSAN for the illustrations and  
information that have made this booklet  
possible**

**ROBERT D. CHERRNAY  
TECHNICAL DIRECTOR**

**DALE ENGLAND  
FIELD SERVICE CONSULTANT**

**WAYNE COLONNA  
TECHNICAL SUPERVISOR**

**ED KRUSE  
TECHNICAL CONSULTANT**

**PETE LUBAN  
TECHNICAL CONSULTANT**

**JIM DIAL  
TECHNICAL CONSULTANT**

**GREGORY LIPNICK  
TECHNICAL CONSULTANT**

**JERRY GOTT  
TECHNICAL CONSULTANT**

**DAVID CHALKER  
TECHNICAL CONSULTANT**

***AUTOMATIC TRANSMISSION SERVICE GROUP***  
9200 S. DADELAND BLVD.  
SUITE 720  
MIAMI, FL 33156  
(305) 670-4161

### Electrical Control Chart

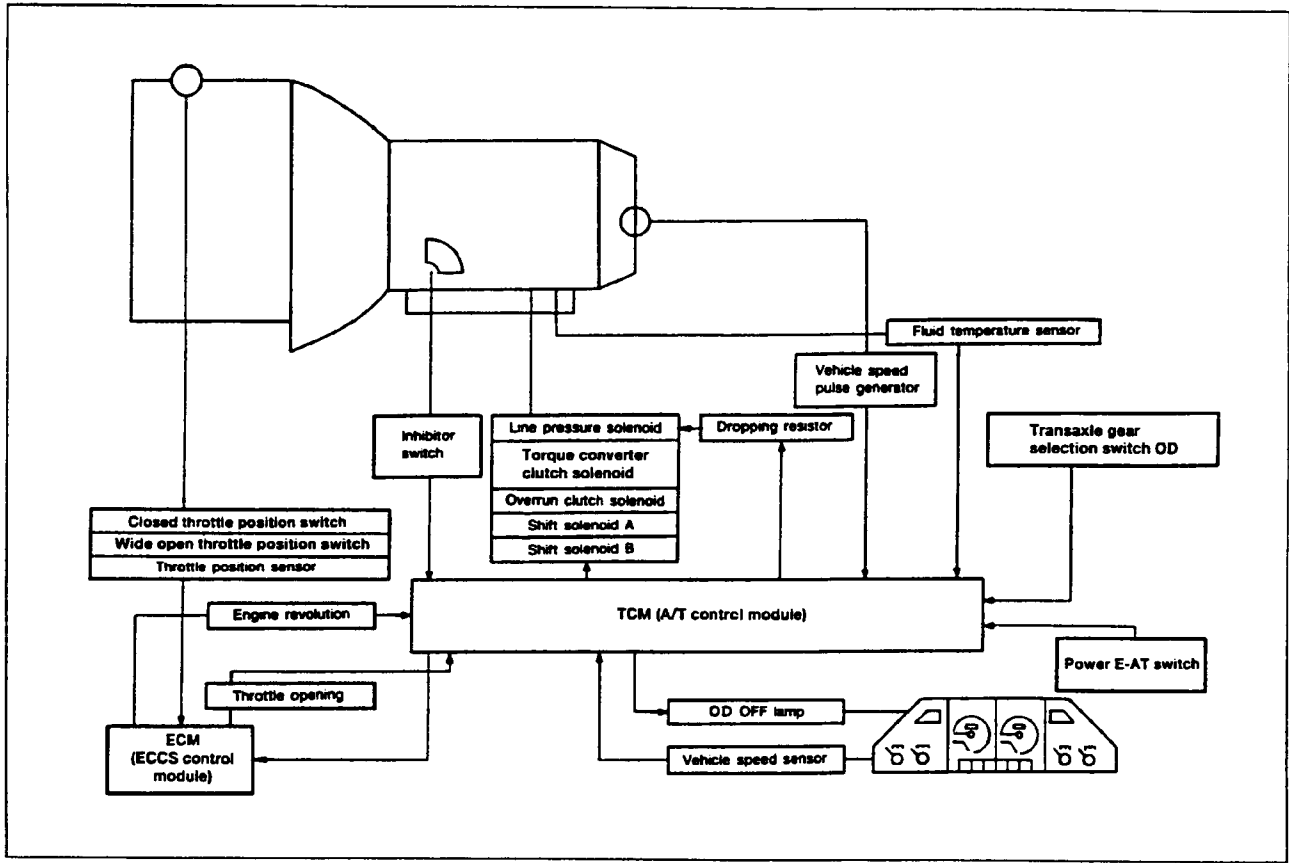

### Mechanical Operation

Shift position	Reverse clutch	High clutch	Forward clutch	Overrun clutch	Band servo			Forward one-way clutch	Low one-way clutch	Low & reverse brake	Lock-up	Remarks
					2nd apply	3rd release	4th apply					
P												PARK
R	○									○		REVERSE
N												NEUTRAL
D*4	1st		○	*1◎				●	●			Automatic shift 1 ↔ 2 ↔ 3 ↔ 4
	2nd		◎	*1◎	○			●				
	3rd		○	◎	*1◎	*2(X)	(X)	●			*1○	
	4th		○	(X)		*3(X)	(X)	○			○	
2	1st		○	○				●	●			Automatic shift 1 ↔ 2 ↔ 3
	2nd		○	○	○			●				
1	1st		○	○				●		○		Locks (held stationary) in 1st speed 1 ← 2 ← 3
	2nd		○	○	○			●				

\*1: Operates when transaxle gear selection switch OD is in "OFF" position.  
 \*2: Oil pressure is applied to both 2nd "apply" side and 3rd "release" side of band servo piston. However, brake band does not contract because oil pressure area on the "release" side is greater than that on the "apply" side.  
 \*3: Oil pressure is applied to 4th "apply" side in condition \*2 above and brake band contracts.  
 \*4: A/T will not shift to 4th when transaxle gear selection switch OD is in "OFF" position.  
 ○: Operates  
 ◎: Operates when throttle opening is less than 3/16. ●: Operates during "progressive" acceleration.  
 (X): Operates but does not affect power transmission.



### A/T Electrical Parts Location

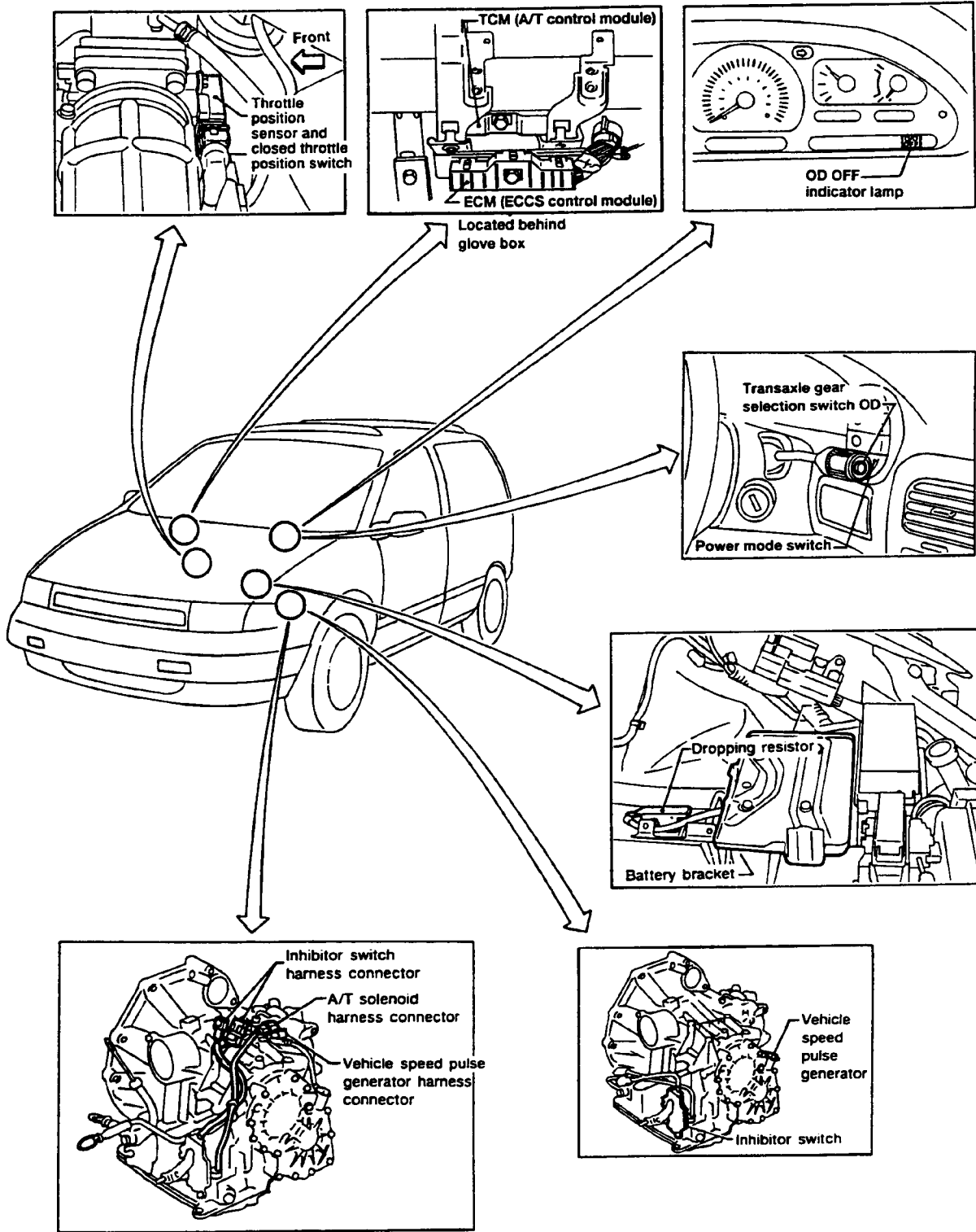



Service Information RE4FO4A

Circuit Diagram for Quick Pinpoint Check

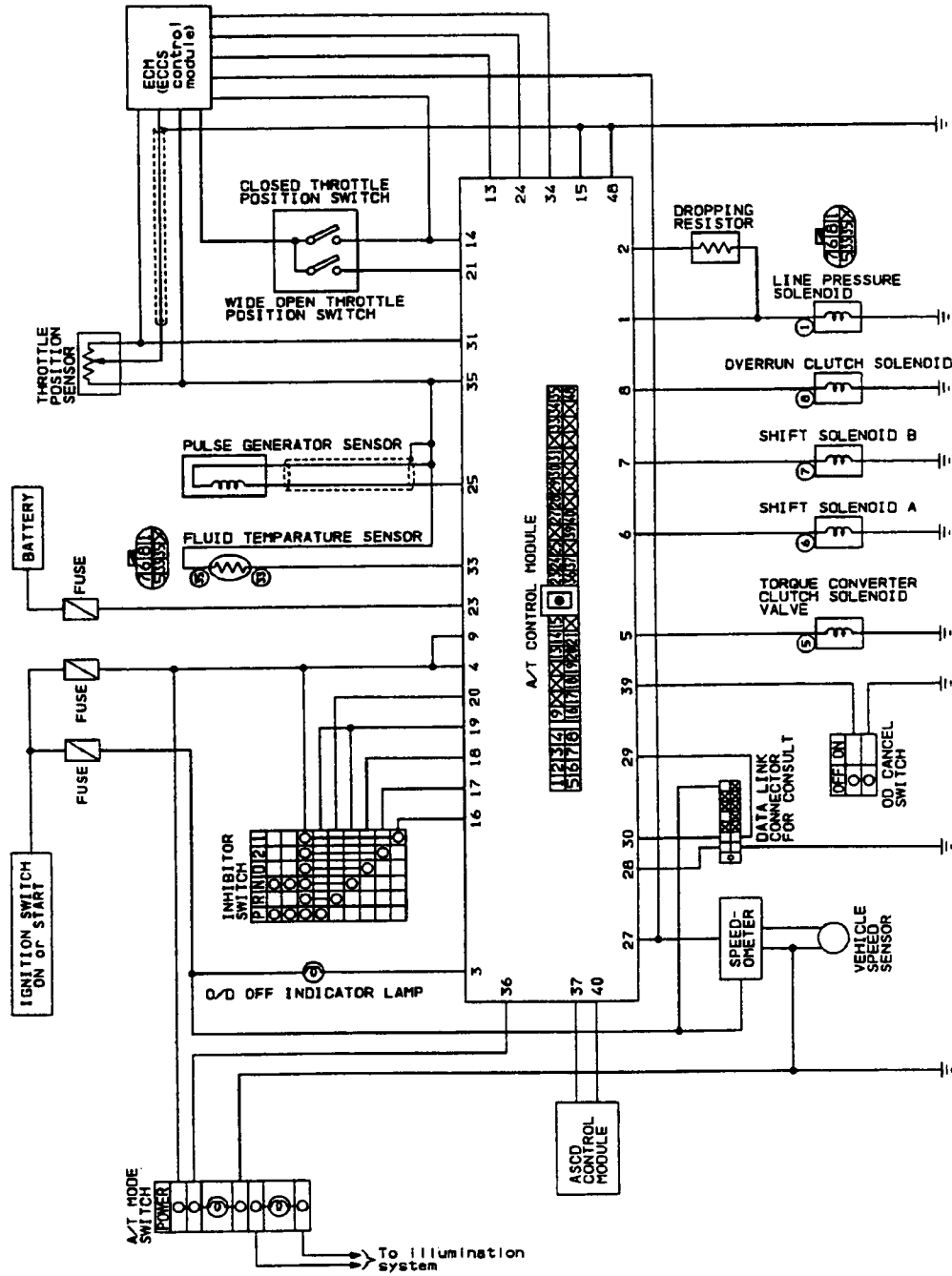

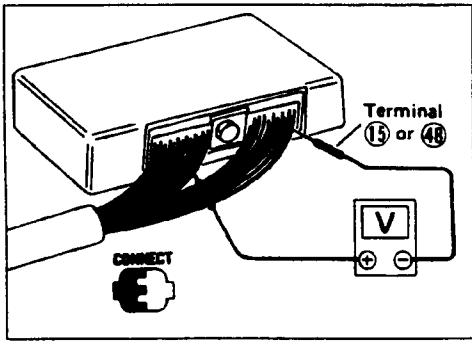

### Electrical Components Inspection

#### INSPECTION OF TCM (A/T CONTROL MODULE)

- Measure voltage between each terminal and terminal 15 or 48 by following "TCM INSPECTION TABLE".
- The TCM is located behind the glove box, above the ECM (ECCS control module).
- Pin connector terminal layout.

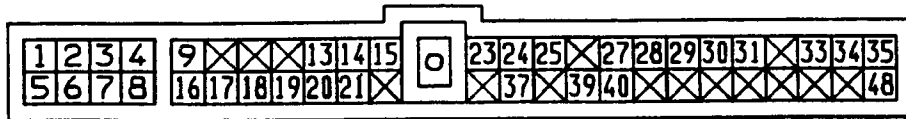

#### TCM INSPECTION TABLE

(Data are reference values.)

Terminal No.	Item	Condition	Judgement standard
1	Line pressure solenoid	When releasing accelerator pedal after warming up engine.	1.5 - 2.5V
		When depressing accelerator pedal fully after warming up engine.	0.5V or less
2	Line pressure solenoid (with dropping resistor)	When releasing accelerator pedal after warming up engine.	5 - 14V
		When depressing accelerator pedal fully after warming up engine.	0.5V or less
3	OD OFF indicator lamp	When setting transaxle gear selection switch-OD in "OFF" position.	1V or less
		When setting transaxle gear selection switch-OD in "ON" position.	Battery positive voltage
4	Power source	When turning ignition switch to "ON".	Battery positive voltage
		When turning ignition switch to "OFF".	1V or less



# TROUBLE DIAGNOSIS RE4FO4A

## Electrical Components Inspection (Cont'd)

Terminal No.	Item	Condition	Judgement standard
5	Torque converter clutch solenoid valve	When A/T performs lock-up.	10 - 16V
		When A/T does not perform lock-up.	1V or less
6	Shift solenoid A	When shift solenoid A operates. (When driving in "D <sub>1</sub> " or "D <sub>4</sub> ".)	Battery positive voltage
		When shift solenoid A does not operate. (When driving in "D <sub>2</sub> " or "D <sub>3</sub> ".)	1V or less
7	Shift solenoid B	When shift solenoid B operates. (When driving in "D <sub>1</sub> " or "D <sub>2</sub> ".)	Battery positive voltage
		When shift solenoid B does not operate. (When driving in "D <sub>3</sub> " or "D <sub>4</sub> ".)	1V or less
8	Overrun clutch solenoid	When overrun clutch solenoid operates.	Battery positive voltage
		When overrun clutch solenoid does not operate.	1V or less
9	Power source	Same as No. 4	
10	--	--	--
11	--	--	--
12	--	--	--
13*	--	--	--
14	Closed throttle position switch	When releasing accelerator pedal after warming up engine.	8 - 15V
		When depressing accelerator pedal after warming up engine.	1V or less
15	Ground	--	--
16	Transaxle gear selection switch-1 range	When setting selector lever to "1" range.	Battery positive voltage
		When setting selector lever to other ranges.	1V or less
17	Transaxle gear selection switch-2 range	When setting selector lever to "2" range.	Battery positive voltage
		When setting selector lever to other ranges.	1V or less
18	Transaxle gear selection switch-D range	When setting selector lever to "D" range.	Battery positive voltage
		When setting selector lever to other ranges.	1V or less
19	Park/Neutral Position switch	When setting selector lever to "N" and "P" ranges.	Battery positive voltage
		When setting selector lever to other ranges.	1V or less
20	Transaxle gear selection switch-Reverse	When setting selector lever to "R" range.	Battery positive voltage
		When setting selector lever to other ranges.	1V or less
21	Wide open throttle position switch	When depressing accelerator pedal more than half-way.	8 - 15V
		When releasing accelerator pedal.	1V or less
22	--	--	--

\*: This terminal is connected to the ECM (ECCS control module).<sup>7</sup>





# TROUBLE DIAGNOSIS RE4FO4A

Terminal No.	Item		Condition	Judgement standard
23	Power source (Back-up)		When turning ignition switch to "OFF".	Battery positive voltage
			When turning ignition switch to "ON".	Battery positive voltage
24	Engine speed signal		When engine runs at idle speed.	1.13 - 1.15V
			When engine runs at 4,000 rpm.	Approximately 5.85V
25	Vehicle speed pulse generator (Measure in AC range)		When vehicle cruises at 30 km/h (19 MPH).	1V or more Voltage rises gradually in response to vehicle speed.
			When vehicle parks.	0V
26	-		-	-
27	Speed sensor		When moving vehicle at 2 to 3 km/h (1 to 2 MPH) for 1 m (3 ft) or more.	Vary from 0 to 5V
28**	-		-	-
29**	-		-	-
30**	-		-	-
31	Throttle position sensor (Power source)		-	4.5 - 5.5V
32	-		-	-
33	Fluid temperature sensor		When ATF temperature is 20°C (68°F).	1.56V
			When ATF temperature is 80°C (176°F).	0.45V
34	Throttle position sensor		When depressing accelerator pedal slowly after warming up engine. (Voltage rises gradually in response to throttle opening angle.)	Fully-closed throttle: 0.2 - 0.6V Fully-open throttle: 2.9 - 3.9V
35	Throttle position sensor (Ground)		-	-
36	Power mode switch		When setting power mode switch "ON".	Battery positive voltage
			When setting power mode switch "OFF".	1V or less
37	ASCD cruise signal		When ASCD cruise is being performed. ("CRUISE" light comes on.)	Battery positive voltage
			When ASCD cruise is not being performed. ("CRUISE" light does not come on.)	1V or less

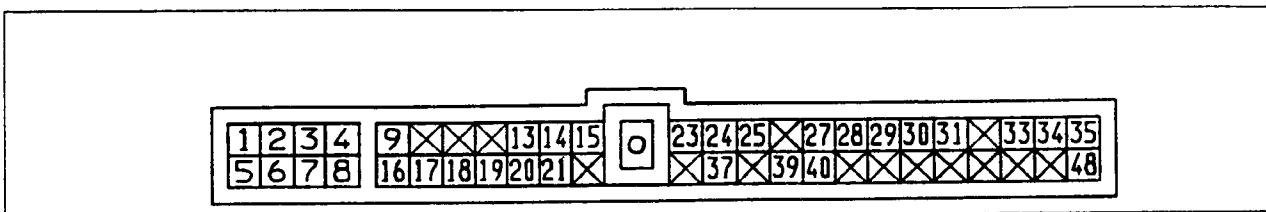
\*\* : These terminals are connected to the data link connector for CONSULT.



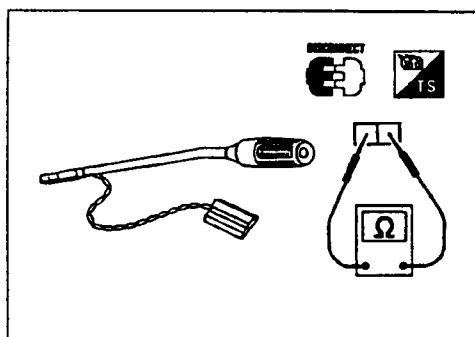

Terminal No.	Item	Condition		Judgement standard
38	--		--	--
39	Transaxle gear selection switch-OD		When setting transaxle gear selection switch-OD in "ON" position.	Battery positive voltage
			When holding transaxle gear selection switch-OD in.	1V or less
40	ASCD OD cut signal		When "ACCEL" set switch on ASCD cruise is released.	5 - 8V
			When "ACCEL" set switch on ASCD cruise is applied.	1V or less
41	--		--	--
42	--		--	--
43	--		--	--
44	--		--	--
45	--		--	--
46	--		--	--
47	--		--	--
48	Ground		--	--

**OVERDRIVE SWITCH**

- Check continuity between two terminals.

Transaxle gear selection switch-OD	Continuity
ON	No
OFF	Yes

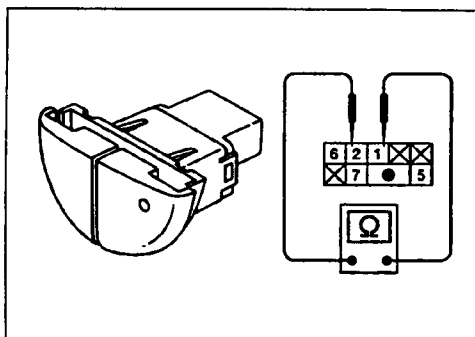
**POWER MODE SWITCH**

- Check continuity between power mode switch terminal.

Power mode switch position	Continuity
ON	① - ②
OFF	No

## INHIBITOR SWITCH

1. Check continuity between terminals ① and ② and between terminals ③ and ④, ⑤, ⑥, ⑦, ⑧, ⑨ while moving selector lever through each range.

Lever position	Terminal No.								
	①	②	③	④	⑤	⑥	⑦	⑧	⑨
P	○—○		○—○						
R			○—○	○—○					
N	○—○		○—○		○—○				
D			○—○	○—○		○—○			
2			○—○	○—○			○—○		
1			○—○	○—○				○—○	

• Terminals ① and ② are utilized in the starter circuit.

2. If N.G., check again with control cable disconnected from manual shaft of A/T assembly. — Refer to step 1.
3. If O.K. on step 2, adjust control cable.
4. If N.G. on step 2, remove inhibitor switch from A/T and check continuity of inhibitor switch terminal. — Refer to step 1.
5. If O.K. on step 4, adjust inhibitor switch.
6. If N.G. on step 4, replace inhibitor switch.

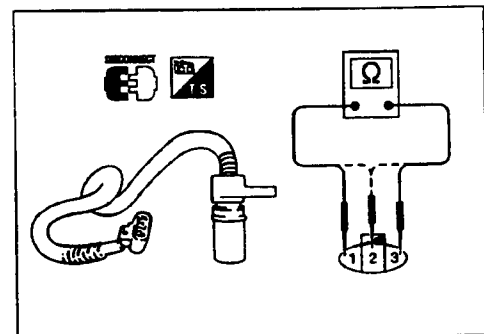
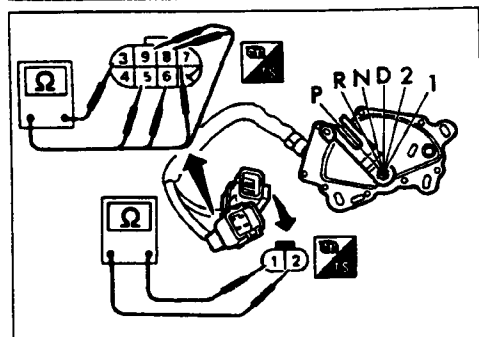
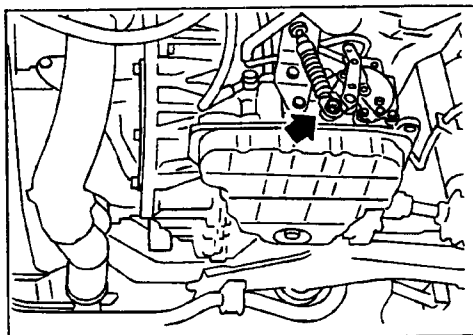
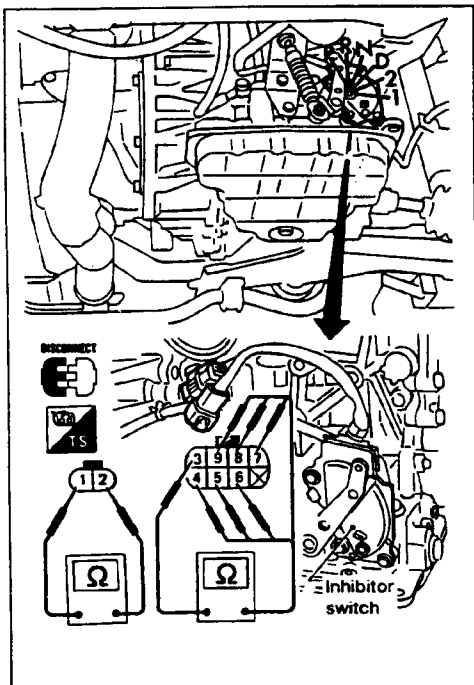

## VEHICLE SPEED PULSE GENERATOR

- Check resistance between terminals ①, ② and ③.

Terminal No.		Resistance
①	②	500 - 650Ω
②	③	No continuity
①	③	No continuity

## SOLENOIDS AND FLUID TEMPERATURE SENSOR

- Check resistance between two terminals.

### Solenoids

Solenoid	Terminal No.	Resistance (Approx.)
Shift solenoid A	②	25Ω
Shift solenoid B	①	
Overrun clutch solenoid	③	3.2Ω
Line pressure solenoid	④	
Torque converter clutch solenoid valve	⑤	13.4Ω



# TROUBLE DIAGNOSIS RE4FO4A

## Electrical Components Inspection (Cont'd)

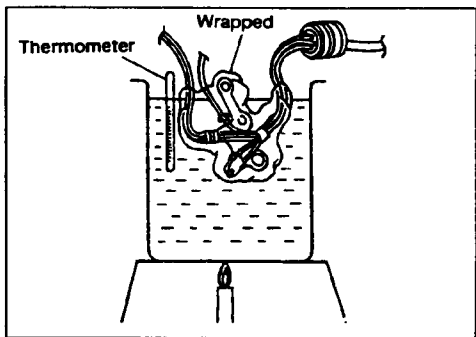
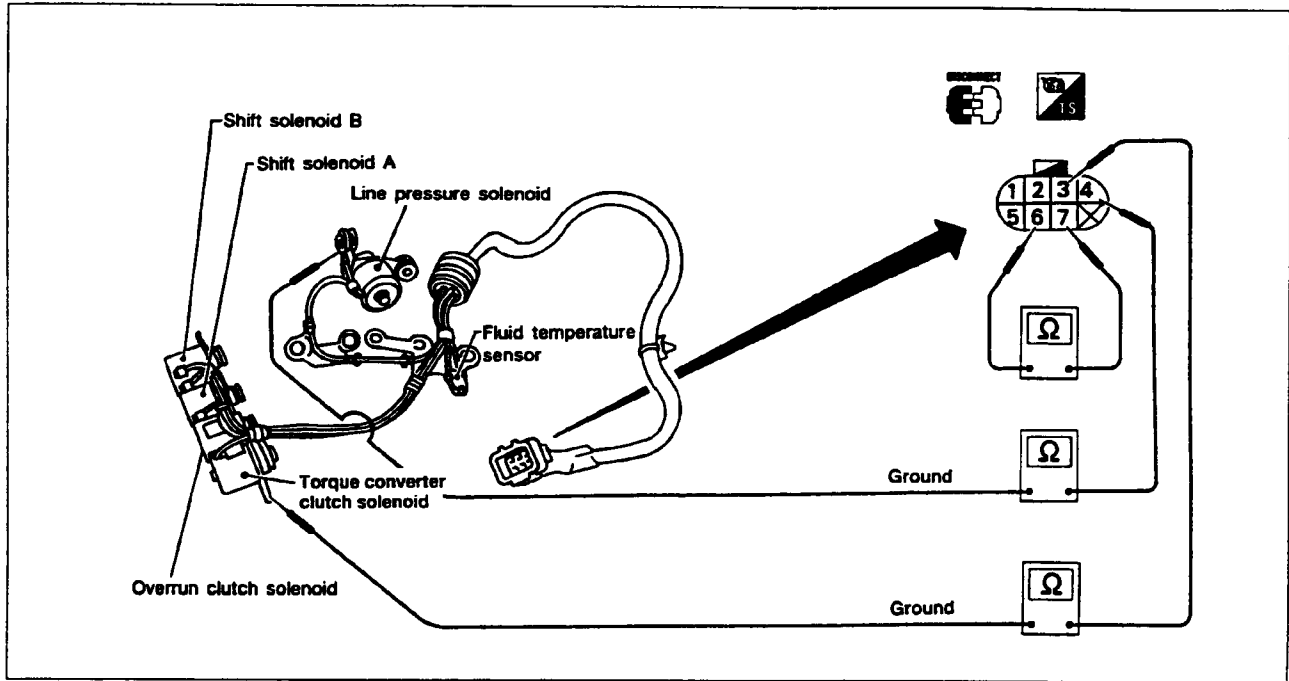

### Fluid temperature sensor

Check resistance between terminals ⑥ and ⑦ while changing temperature as shown at left.

Temperature °C (°F)	Resistance (Approx.)
20 (68)	2.5 kΩ
80 (176)	0.3 kΩ

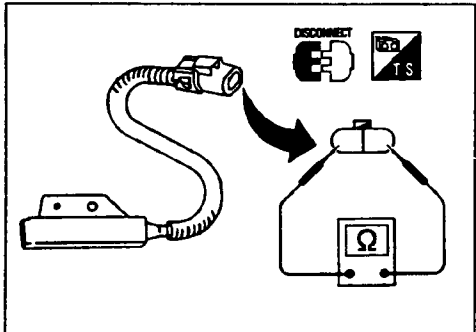

### DROPPING RESISTOR

- Check resistance between two terminals.  
Resistance: 11.2 - 12.8Ω

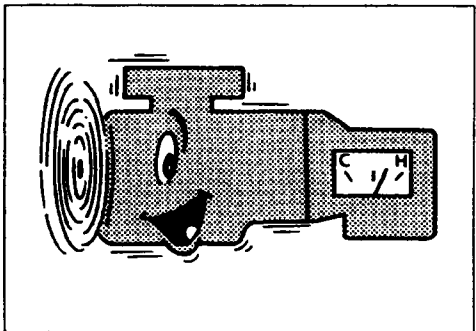

### Final Check

#### STALL TESTING

##### Stall test procedure

1. Check A/T and engine fluid levels. If necessary, add.
2. Warm up engine until engine oil and ATF reach operating temperature after vehicle has been driven approx. 10 minutes.

**ATF operating temperature:**  
66 - 77°C (151 - 171°F)



## TROUBLE DIAGNOSIS RE4FO4A

### Final Check (Cont'd)

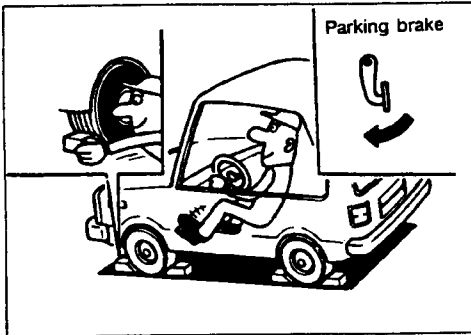

3. Set parking brake and block wheels.
4. Install a tachometer where it can be seen by driver during test.
  - It is good practice to put a mark on point of specified engine rpm on indicator.

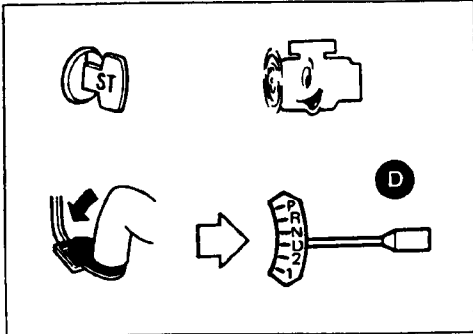

5. Start engine, apply foot brake, and place selector lever in "D" range.

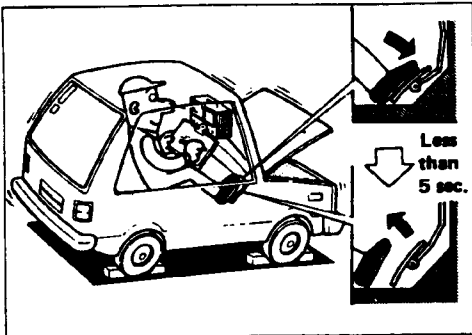

6. Accelerate to wide-open throttle gradually while applying foot brake.
7. Quickly note the engine stall revolution and immediately release throttle.
  - During test, never hold throttle wide-open for more than 5 seconds.

Stall revolution:  
1,800 - 2,100 rpm

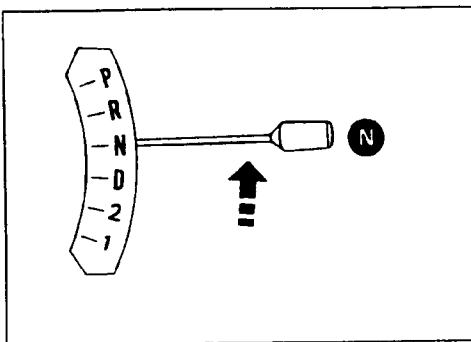

8. Shift selector lever to "N".
9. Cool off ATF
  - Run engine at idle for at least one minute.
10. Perform stall tests in the same manner as in steps 5 through 9 with selector lever in "2", "1" and "R", respectively.



# TROUBLE DIAGNOSIS RE4F04A

## Judgement of stall test

Selector lever position	Judgement		
D	H	O	L
2	H	O	L
1	O	O	L
R	H	H	L

O : Stall revolution is normal.  
 H : Stall revolution is higher than specified.  
 L : Stall revolution is lower than specified.

Damaged components

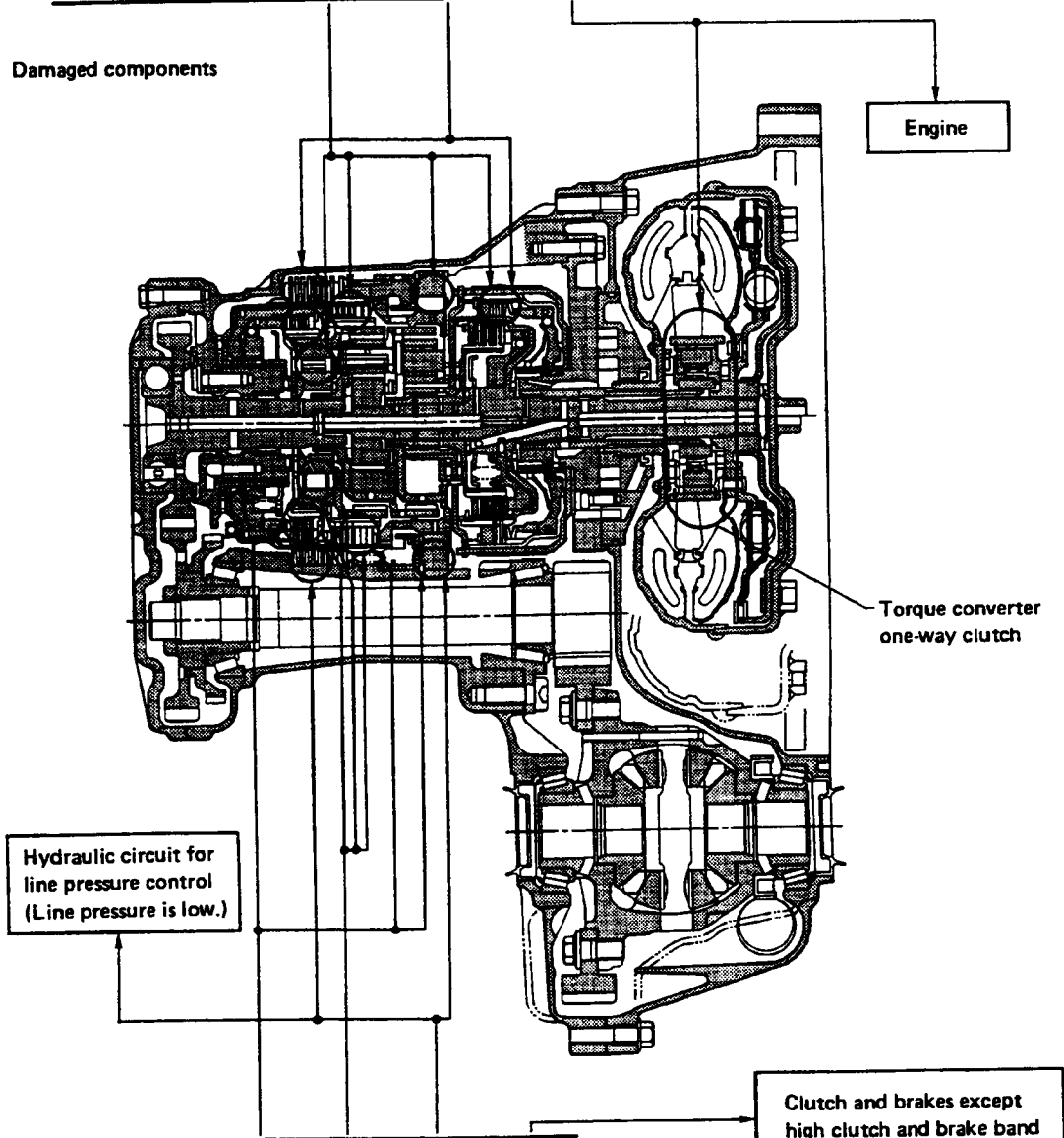

D	H	H	H	O
2	H	H	H	O
1	O	H	H	O
R	O	O	H	O
Selector lever position	Judgement			

Clutch and brakes except high clutch and brake band are O.K. (Condition of high clutch and brake band cannot be confirmed by stall test.)

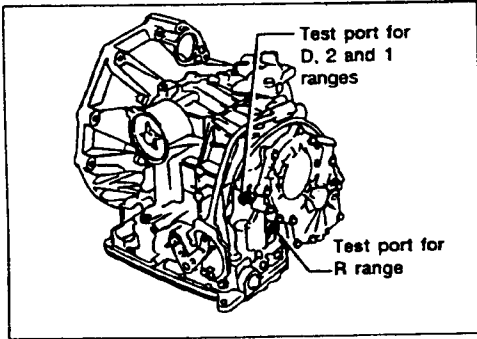

**PRESSURE TESTING**

- Location of line pressure test port
- **Always replace pressure plugs as they are self-sealing bolts.**

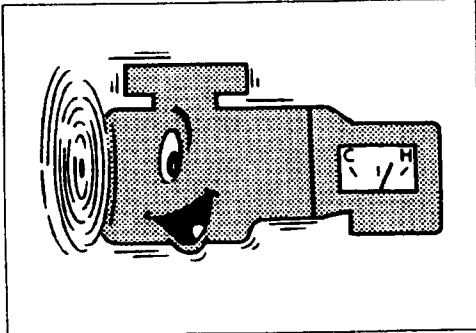

**Line pressure test procedure**

1. Check A/T and engine fluid levels. If necessary, add fluid.
2. Warm up engine until engine oil and ATF reach operating temperature after vehicle has been driven approx. 10 minutes.

**ATF operating temperature:  
66 - 77°C (151 - 171°F)**

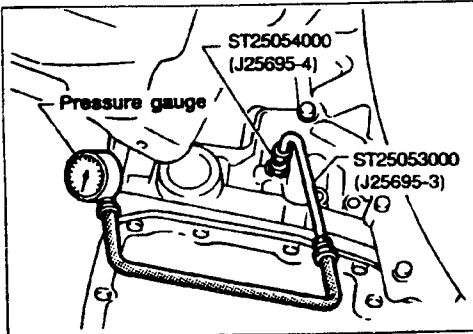

3. Install pressure gauge to corresponding line pressure port.

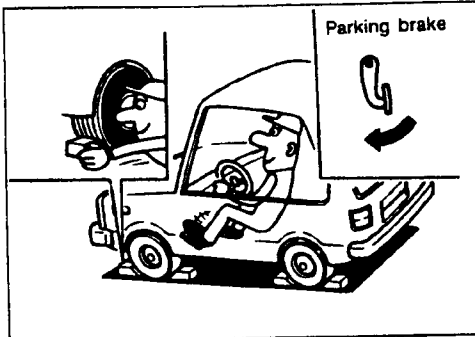

4. Set parking brake and block wheels.
  - **Continue to depress brake pedal fully while line pressure test is being performed at stall speed.**



**TROUBLE DIAGNOSIS RE4FO4A**

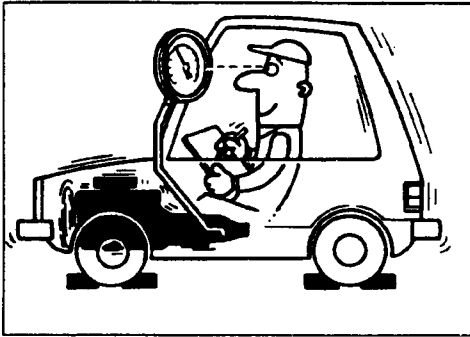

5. Start engine and measure line pressure at idle and stall speed.
- **When measuring line pressure at stall speed, follow the stall test procedure.**

**Line pressure:**

Engine speed rpm	Line pressure (Approx.) kPa (kg/cm <sup>2</sup> , psi)	
	D, 2 and 1 ranges	R range
Idle	500 (5.1, 73)	775 (7.9, 112)
Stall	1,226 (12.5, 178)	1,961 (20.0, 284)

**JUDGEMENT OF LINE PRESSURE TEST**

Judgement		Suspected parts
At idle	Line pressure is low in all ranges.	<ul style="list-style-type: none"> <li>• Oil pump wear</li> <li>• Pressure regulator valve or plug sticking</li> <li>• Spring for pressure regulator valve damaged</li> <li>• Fluid pressure leakage between oil strainer and pressure regulator valve</li> </ul>
	Line pressure is low in particular range.	<ul style="list-style-type: none"> <li>• Fluid pressure leakage between manual valve and particular clutch</li> <li>• For example; If line pressure is low in "R" and "1" ranges but is normal in "D" and "2" range, fluid leakage exists at or around low &amp; reverse brake circuit.</li> </ul>
	Line pressure is high.	<ul style="list-style-type: none"> <li>• Mal-adjustment of throttle position sensor</li> <li>• Fluid temperature sensor damaged</li> <li>• Line pressure solenoid sticking</li> <li>• Short circuit of line pressure solenoid circuit</li> <li>• Pressure modifier valve sticking</li> <li>• Pressure regulator valve or plug sticking</li> </ul>
At stall speed	Line pressure is low.	<ul style="list-style-type: none"> <li>• Mal-adjustment of throttle position sensor</li> <li>• Line pressure solenoid sticking</li> <li>• Short circuit of line pressure solenoid circuit</li> <li>• Pressure regulator valve or plug sticking</li> <li>• Pressure modifier valve sticking</li> <li>• Pilot valve sticking</li> </ul>



# TROUBLE DIAGNOSIS RE4FO4A

## Symptom Chart

Numbers are arranged in order of probability. Perform inspections starting with number one and working up. Circled numbers indicate that the transmission must be removed from the vehicle.

	Fluid level	Control linkage	Inhibitor switch	Throttle position sensor (Adjustment)	Vehicle speed pulse generator and speed sensor	Engine speed signal	Engine idling rpm	Line pressure	Control valve assembly	Shift solenoid A	Shift solenoid B	Line pressure solenoid	Torque converter clutch solenoid valve	Overrun clutch solenoid	Fluid temperature sensor	Accumulator N-D	Accumulator 3-R	Ignition switch and starter	Torque converter	Oil pump	Reverse clutch	High clutch	Forward clutch	Forward one-way clutch	Overrun clutch	Low one-way clutch	Low & reverse brake	Brake band	Parking components	
59 Engine does not start in "N", "P" ranges.	.	2	3	.	.	.	.	.	.	.	.	.	.	.	.	.	.	1	.	.	.	.	.	.	.	.	.	.	.	
59 Engine starts in range other than "N" and "P".	.	1	2	.	.	.	.	.	.	.	.	.	.	.	.	.	.	.	.	.	.	.	.	.	.	.	.	.	.	
- Transmission noise in "P" and "N" ranges.	1	.	3	4	5	.	2	.	.	.	.	.	.	.	.	.	.	.	7	6	.	.	.	.	.	.	.	.	.	
59 Vehicle moves when changing into "P" range or parking gear does not disengage when shifted out of "P" range.	.	1	.	.	.	.	.	.	.	.	.	.	.	.	.	.	.	.	.	.	.	.	.	.	.	.	.	2		
60 Vehicle runs in "N" range.	.	1	.	.	.	.	.	.	.	.	.	.	.	.	.	.	.	.	.	.	3	2	4	.	.	.	.	.	.	
62 Vehicle will not run in "R" range (but runs in "D", "2" and "1" ranges). Clutch slips. Very poor acceleration.	.	1	.	.	.	.	2	4	.	3	.	.	.	.	.	.	.	.	.	.	5	6	7	8	9	.	.	.	.	
- Vehicle braked when shifting into "R" range.	1	2	.	.	.	.	3	5	.	4	.	.	.	.	.	.	.	.	.	.	6	8	9	.	.	7	.	.	.	
- Sharp shock in shifting from "N" to "D" range.	.	.	2	.	5	1	3	7	.	6	.	.	.	.	4	8	.	.	.	.	.	9	.	.	.	.	.	.	.	.
- Vehicle will not run in "D" and "2" ranges (but runs in "1" and "R" range).	.	1	.	.	.	.	.	.	.	.	.	.	.	.	.	.	.	.	.	.	.	.	.	.	2	.	.	.	.	
63 Vehicle will not run in "D", "1", "2" ranges (but runs in "R" range). Clutch slips. Very poor acceleration.	1	.	.	.	.	.	2	4	.	3	.	.	.	.	.	5	.	.	.	.	6	7	8	9	10	.	.	.	.	.
- Clutches or brakes slip somewhat in starting.	1	2	3	.	.	.	4	6	.	5	.	.	.	.	.	7	.	.	.	12	11	9	8	.	.	10	.	.	.	
- Excessive creep.	.	.	.	.	.	.	1	.	.	.	.	.	.	.	.	.	.	.	.	.	.	.	.	.	.	.	.	.	.	
62, 63 No creep at all.	1	.	.	.	.	.	2	3	.	.	.	.	.	.	.	.	.	.	.	6	5	.	4	.	.	.	.	.	.	
- Failure to change gear from "D <sub>1</sub> " to "D <sub>2</sub> ".	.	2	1	.	5	.	.	4	3	.	.	.	.	.	.	.	.	.	.	.	.	.	.	.	.	.	6	.	.	
- Failure to change gear from "D <sub>2</sub> " to "D <sub>3</sub> ".	.	2	1	.	5	.	.	4	3	.	.	.	.	.	.	.	.	.	.	.	6	.	.	.	.	.	7	.	.	
- Failure to change gear from "D <sub>3</sub> " to "D <sub>4</sub> ".	.	2	1	.	4	.	.	3	.	.	.	.	.	.	5	.	.	.	.	.	.	.	.	.	.	.	6	.	.	
65, 67, 68 Too high gear change point from "D <sub>1</sub> " to "D <sub>2</sub> ", from "D <sub>2</sub> " to "D <sub>3</sub> ", from "D <sub>3</sub> " to "D <sub>4</sub> ".	.	.	1	2	.	.	.	3	4	.	.	.	.	.	.	.	.	.	.	.	.	.	.	.	.	.	.	.	.	
- Gear change directly from "D <sub>1</sub> " to "D <sub>3</sub> " occurs.	1	.	.	.	.	.	.	.	.	.	.	.	.	.	.	.	2	.	.	.	.	.	.	.	.	.	3	.	.	
- Engine stops when shifting lever into "R", "D", "2" and "1".	.	.	.	.	.	.	1	3	.	.	.	2	.	.	.	.	.	.	.	4	.	.	.	.	.	.	.	.	.	
- Too sharp a shock in change from "D <sub>1</sub> " to "D <sub>2</sub> ".	.	.	1	.	.	.	2	4	.	.	.	.	.	.	5	3	.	.	.	.	.	.	.	.	.	.	6	.	.	
- Too sharp a shock in change from "D <sub>2</sub> " to "D <sub>3</sub> ".	.	.	1	.	.	.	2	3	.	.	.	.	.	.	.	.	.	.	.	.	.	4	.	.	.	.	5	.	.	





# TROUBLE DIAGNOSIS RE4FO4A

## Symptom Chart (Cont'd)

	Fluid level	Control linkage	Inhibitor switch	Throttle position sensor (Adjustment)	Vehicle speed pulse generator and speed sensor	Engine speed signal	Engine idling rpm	Line pressure	Control valve assembly	Shift solenoid A	Shift solenoid B	Line pressure solenoid	Torque converter clutch solenoid valve	Overrun clutch solenoid	Fluid temperature sensor	Accumulator N-D	Accumulator 3-R	Ignition switch and starter	Torque converter	Oil pump	Reverse clutch	High clutch	Forward clutch	Forward one-way clutch	Overrun clutch	Low one-way clutch	Low & reverse brake	Brake band	Parking components
Numbers are arranged in order of probability. Perform inspections starting with number one and working up. Circled numbers indicate that the transmission must be removed from the vehicle.																													
- Too sharp a shock in change from "D <sub>3</sub> " to "D <sub>4</sub> ".			1			2	3																	5			4		
- Almost no shock or clutches slipping in change from "D <sub>1</sub> " to "D <sub>3</sub> ".	1		2			3	5									4											6		
- Almost no shock or slipping in change from "D <sub>2</sub> " to "D <sub>3</sub> ".	1		2			3	4															5					6		
- Almost no shock or slipping in change from "D <sub>3</sub> " to "D <sub>4</sub> ".	1		2			3	4															5					6		
- Vehicle braked by gear change from "D <sub>1</sub> " to "D <sub>2</sub> ".	1																				2	4			5	3			
- Vehicle braked by gear change from "D <sub>2</sub> " to "D <sub>3</sub> ".	1																										2		
- Vehicle braked by gear change from "D <sub>3</sub> " to "D <sub>4</sub> ".	1																				4		3	2					
- Maximum speed not attained. Acceleration poor.	1	2					5	3	4										11	10	6	7				9	8		
- Failure to change gear from "D <sub>4</sub> " to "D <sub>3</sub> ".	1		2					6	4	5	3														8	7			
- Failure to change gear from "D <sub>3</sub> " to "D <sub>2</sub> " or from "D <sub>4</sub> " to "D <sub>3</sub> ".	1		2					5	3	4												6					7		
- Failure to change gear from "D <sub>2</sub> " to "D <sub>1</sub> " or from "D <sub>3</sub> " to "D <sub>1</sub> ".	1		2					5	3	4												7				6	8		
- Gear change shock felt during deceleration by releasing accelerator pedal.			1			2	4					3																	
- Too high a change point from "D <sub>4</sub> " to "D <sub>3</sub> ", from "D <sub>3</sub> " to "D <sub>2</sub> ", from "D <sub>2</sub> " to "D <sub>1</sub> ".			1	2																									
- Kickdown does not operate when depressing pedal in "D <sub>4</sub> " within kickdown vehicle speed.			1	2			3	4																					
- Kickdown operates or engine overruns when depressing pedal in "D <sub>4</sub> " beyond kickdown vehicle speed limit.			2	1			3	4																					
- Races extremely fast or slips in changing from "D <sub>4</sub> " to "D <sub>3</sub> " when depressing pedal.	1		2			3	5		4													6	7						
- Races extremely fast or slips in changing from "D <sub>4</sub> " to "D <sub>2</sub> " when depressing pedal.	1		2			3	6	5	4														8				7		
- Races extremely fast or slips in changing from "D <sub>3</sub> " to "D <sub>2</sub> " when depressing pedal.	1		2			3	5		4		8											9	7				6		
- Races extremely fast or slips in changing from "D <sub>4</sub> " or "D <sub>3</sub> " to "D <sub>1</sub> " when depressing pedal.	1		2			3	5		4														6	7	8				
- Vehicle will not run in any range.	1	2				3			4										9	5	6					8	7	10	
- Transmission noise in "D", "2", "1" and "R" ranges.	1																		2										



# TROUBLE DIAGNOSIS RE4F04A

## Symptom Chart (Cont'd)

Numbers are arranged in order of probability. Perform inspections starting with number one and working up. Circled numbers indicate that the transmission must be removed from the vehicle.		Fluid level	Control linkage	Inhibitor switch	Throttle position sensor (Adjustment)	Vehicle speed pulse generator and speed sensor	Engine speed signal	Engine idling rpm	Line pressure	Control valve assembly	Shift solenoid A	Shift solenoid B	Line pressure solenoid	Torque converter clutch solenoid valve	Overrun clutch solenoid	Fluid temperature sensor	Accumulator N-D	Accumulator 3-R	Ignition switch and starter	Torque converter	Oil pump	Reverse clutch	High clutch	Forward clutch	Forward one-way clutch	Overrun clutch	Low one-way clutch	Low & reverse brake	Brake band	Parking components	
74	Failure to change from "D <sub>3</sub> " to "2" when changing lever into "2" range.	.	7	1	2	.	.	.	.	6	5	4	.	3	.	.	.	.	.	.	.	.	.	.	.	⑥	.	⑥	.	.	
-	Gear change from "2 <sub>2</sub> " to "2 <sub>3</sub> " in "2" range.	.	.	1	.	.	.	.	.	.	.	.	.	.	.	.	.	.	.	.	.	.	.	.	.	.	.	.	.	.	
75	Engine brake does not operate in "1" range.	.	2	1	3	4	.	.	.	6	5	.	.	7	.	.	.	.	.	.	.	.	.	.	.	⑥	.	⑨	.	.	
-	Gear change from "1 <sub>1</sub> " to "1 <sub>2</sub> " in "1" range.	.	2	1	.	.	.	.	.	.	.	.	.	.	.	.	.	.	.	.	.	.	.	.	.	.	.	.	.	.	
-	Does not change from "1 <sub>2</sub> " to "1 <sub>1</sub> " in "1" range.	.	.	1	.	2	.	.	.	4	3	.	.	5	.	.	.	.	.	.	.	.	.	.	.	⑥	.	⑦	.	.	
-	Large shock changing from "1 <sub>2</sub> " to "1 <sub>1</sub> " in "1" range.	.	.	.	.	.	.	.	.	1	.	.	.	.	.	.	.	.	.	.	.	.	.	.	.	.	②	.	.	.	
-	Transmission overheats.	1	.	.	3	.	.	2	4	6	.	.	5	.	.	.	.	.	.	⑭	⑦	⑧	⑨	⑪	.	⑫	.	⑬	⑩	.	
-	ATF shoots out during operation.	1	.	.	.	.	.	.	.	.	.	.	.	.	.	.	.	.	.	.	.	②	③	⑤	.	⑥	.	⑦	④	.	
-	White smoke emitted from exhaust pipe during operation.	1	.	.	.	.	.	.	.	.	.	.	.	.	.	.	.	.	.	.	.	②	③	⑤	.	⑥	.	⑦	④	.	
-	Offensive smell at fluid charging pipe.	1	.	.	.	.	.	.	.	.	.	.	.	.	.	.	.	.	.	.	②	③	④	⑤	⑦	.	⑧	.	⑨	⑥	.
-	Torque converter is not locked up.	.	.	3	1	2	4	.	6	8	.	.	7	.	5	.	.	.	.	⑨	.	.	.	.	.	.	.	.	.	.	.
-	Lock-up piston slip	1	.	.	2	.	.	3	6	.	5	4	.	.	.	.	.	.	.	⑦	.	.	.	.	.	.	.	.	.	.	.
69	Lock-up point is extremely high or low.	.	.	.	1	2	.	.	.	4	.	.	3	.	.	.	.	.	.	.	.	.	.	.	.	.	.	.	.	.	
-	A/T does not shift to "D <sub>4</sub> " when driving with transaxle gear selection switch-OD.	.	.	2	1	3	.	8	6	4	.	.	5	7	.	.	.	.	.	.	.	.	.	.	.	⑩	.	⑨	.	.	
-	Engine is stopped at "R", "D", "2" and "1" ranges.	1	.	.	.	.	.	.	5	4	3	.	2	.	.	.	.	.	.	.	.	.	.	.	.	.	.	.	.	.	

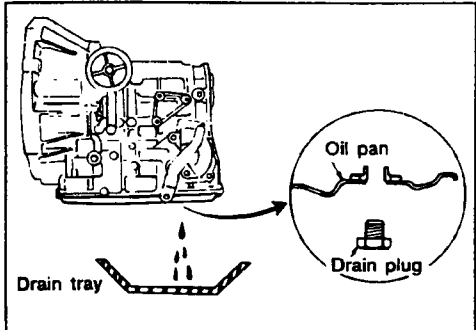

1. Drain ATF through drain plug.

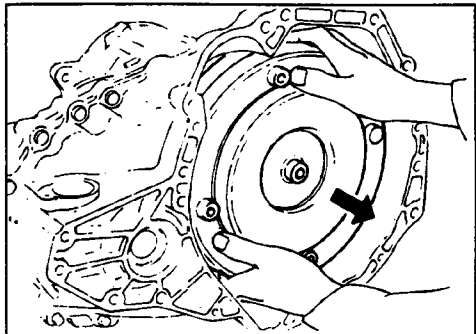

2. Remove torque converter.

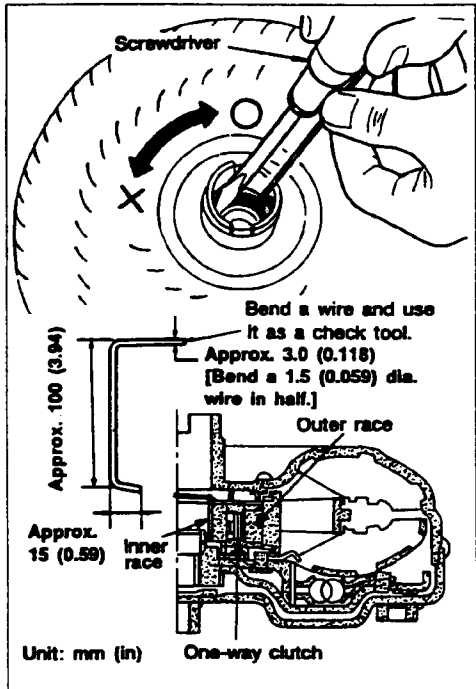

3. Check torque converter one-way clutch using check tool as shown at left.

- a. Insert check tool into the groove of bearing support built into one-way clutch outer race.
- b. When fixing bearing support with check tool, rotate one-way clutch spline using screwdriver.
- c. Check that inner race rotates clockwise only. If not, replace torque converter assembly.

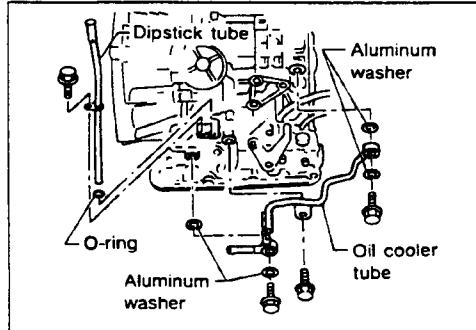

4. Remove oil charging pipe and oil cooler tube.

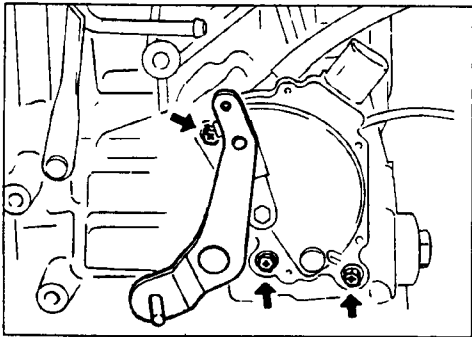

5. Set manual lever to position "P".
6. Remove inhibitor switch.

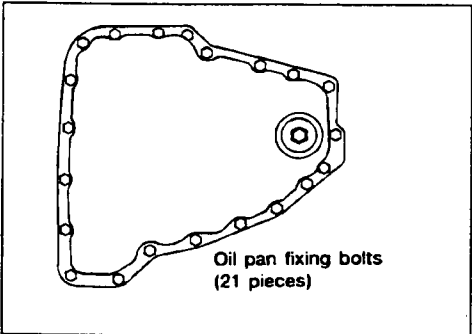

7. Remove oil pan and oil pan gasket.
  - Do not reuse oil pan bolts.

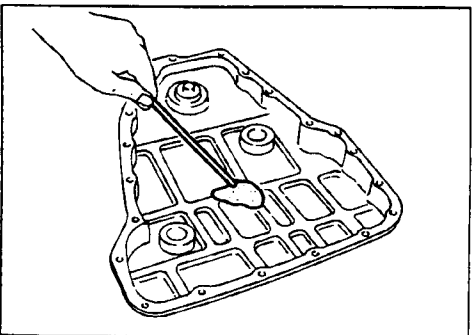

8. Analyze foreign materials in oil pan to trace possible causes of malfunction. If the fluid is very dark, smells burned, or contains foreign particles, the frictional material (clutches, band) may need replacement. A tacky film that will not wipe clean indicates varnish build up which can cause valves, servo, and clutches to stick and may inhibit pump pressure.

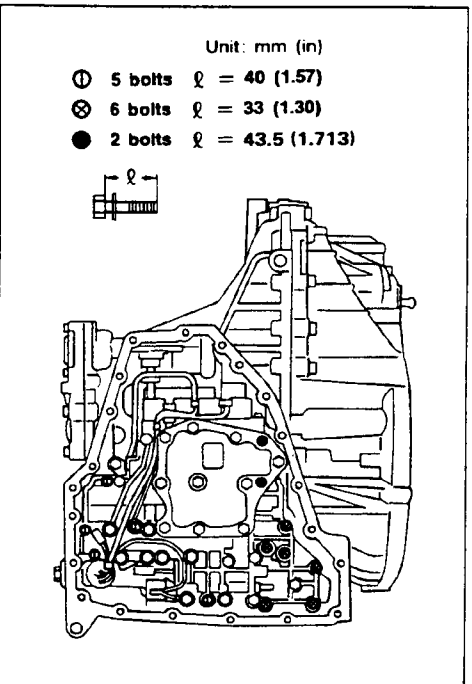

9. Remove control valve assembly according to the following procedures.
  - a. Remove control valve assembly mounting bolts ①, ⊗ and ●.

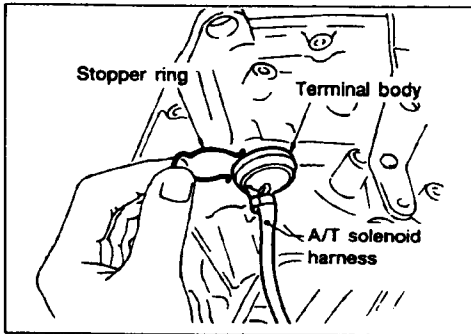

b. Remove stopper ring from terminal body.

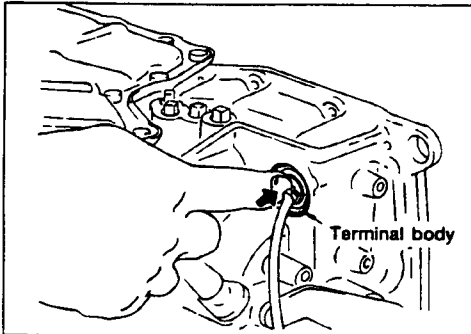

c. Push terminal body into transmission case and draw out solenoid harness.

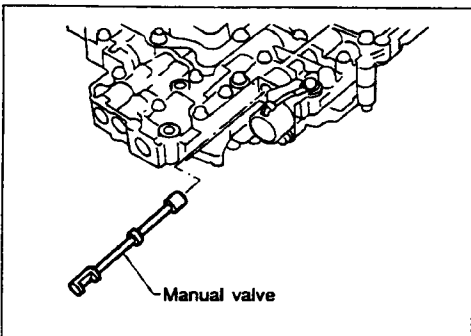

10. Remove manual valve from control valve assembly.

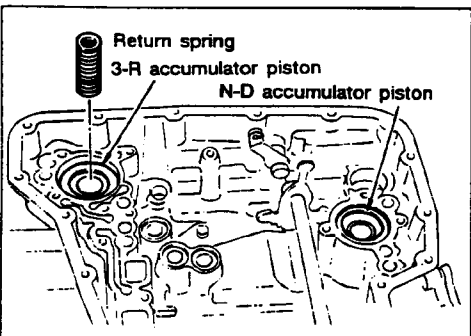

11. Remove return spring from 3-R accumulator piston.

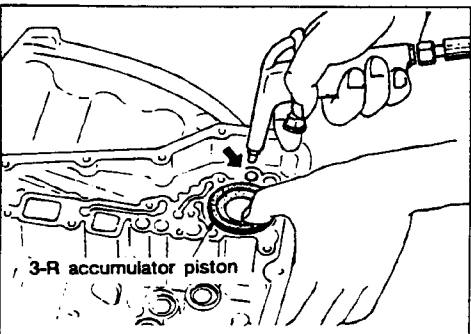

12. Remove 3-R accumulator piston with compressed air.  
13. Remove O-rings from 3-R accumulator piston.

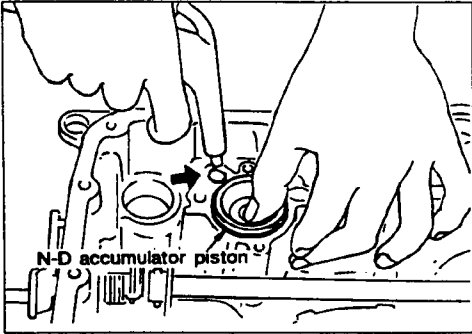

14. Remove N-D accumulator piston and return spring with compressed air.
15. Remove O-rings from N-D accumulator piston.

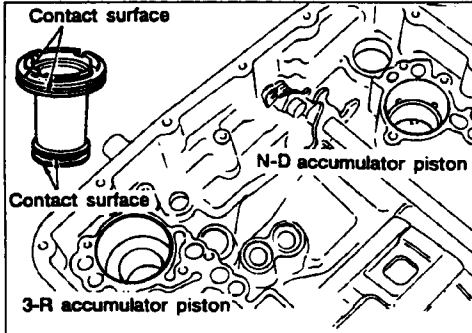

16. Check accumulator pistons and contact surface of transmission case for damage.
17. Check accumulator return springs for damage and free length.

Unit: mm (in)

Spring	Free length	Outer diameter
3-R accumulator spring	52.5 (2.067 )	20.1 (0.791)
N-D accumulator spring	43.5 (1.713 )	27.0 (1.063)

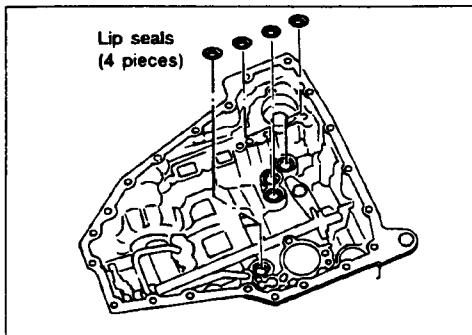

18. Remove lip seals.

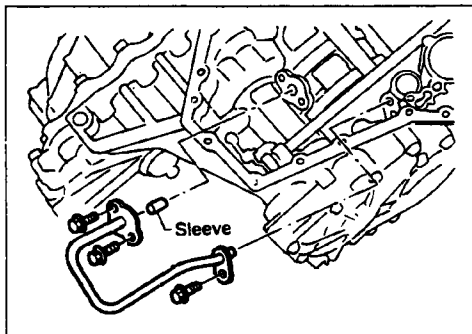

19. Remove tube and sleeve.

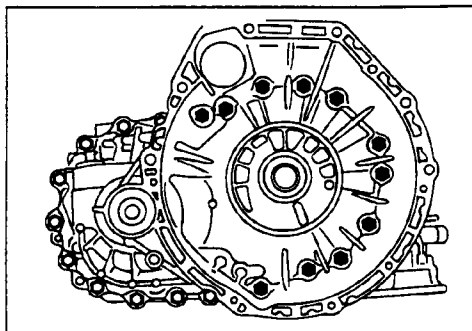

20. Remove converter housing according to the following procedures.
  - a. Remove converter housing mounting bolts.

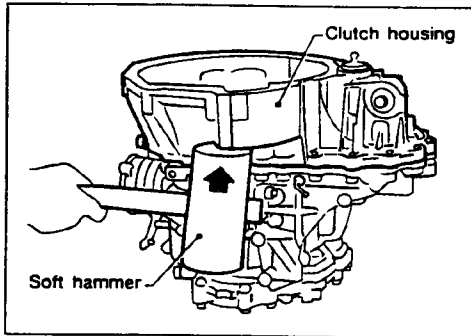

b. Remove converter housing by tapping it lightly.

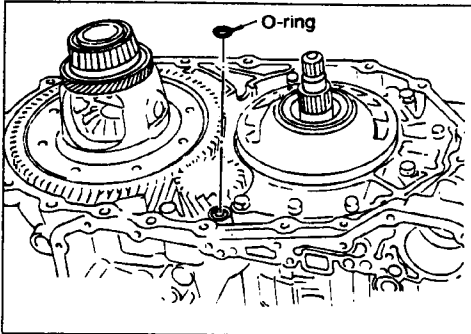

c. Remove O-ring from differential oil port.

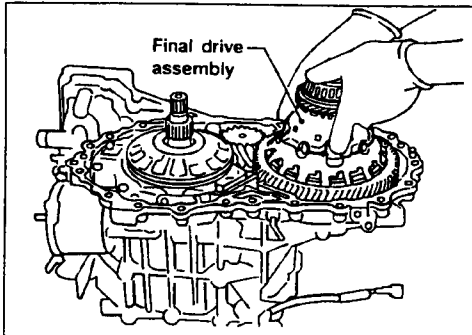

21. Remove final drive assembly from transmission case.

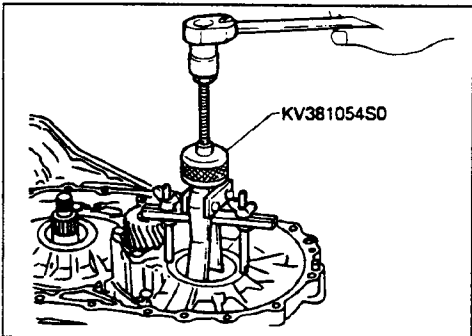

22. Remove differential side bearing outer race from transmission case.

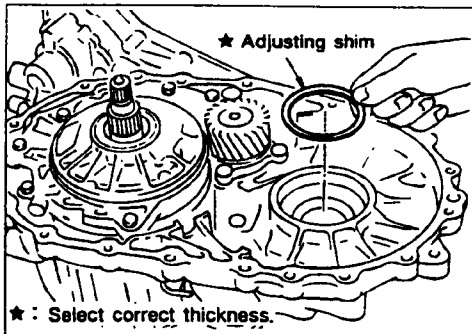

23. Remove differential side bearing adjusting shim from transmission case.

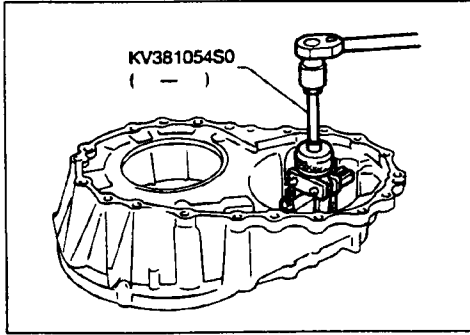

24. Remove differential side bearing outer race from converter housing.

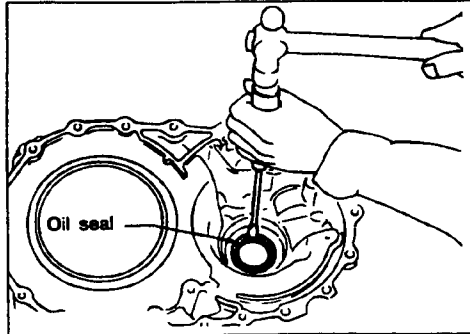

25. Remove oil seal with screwdriver from converter housing.  
 ● Be careful not to damage case.

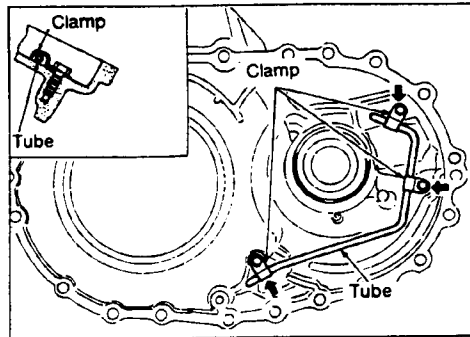

26. Remove oil tube from converter housing.

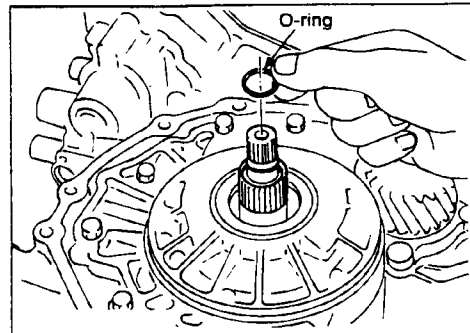

27. Remove oil pump according to the following procedures.  
 a. Remove O-ring from input shaft.

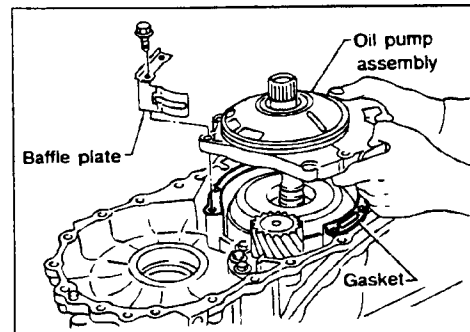

b. Remove oil pump assembly, baffle plate and gasket from transmission case.





## Service Information RE4FO4A

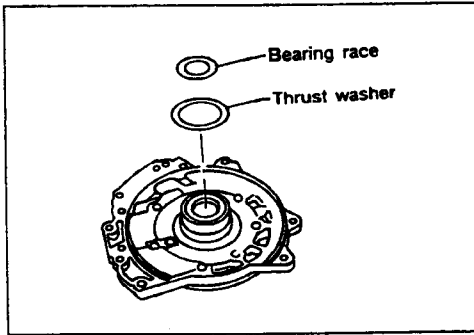

- c. Remove thrust washer and bearing race from oil pump assembly.

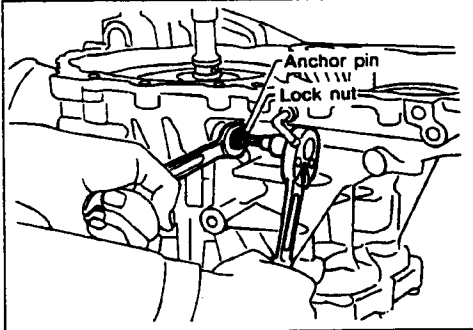

28. Remove brake band according to the following procedures.  
a. Loosen lock nut, then back off band servo anchor end pin.

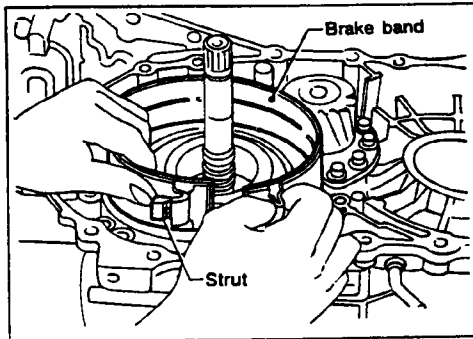

- b. Remove brake band and strut from transmission case.

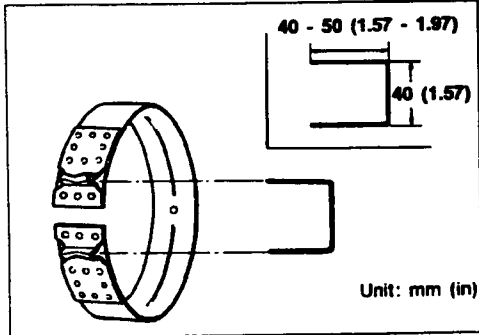

- To prevent brake linings from cracking or peeling, do not stretch the flexible band unnecessarily. When removing the brake band, always secure it with a clip as shown in the figure at left. Leave the clip in position after removing the brake band.

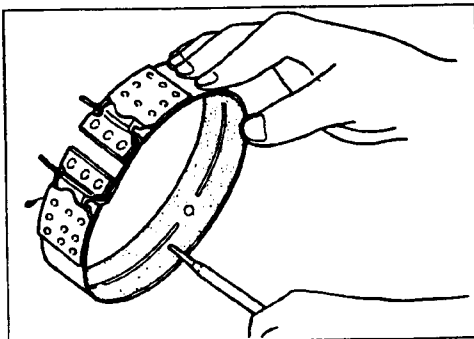

- c. Check brake band facing for damage, cracks, wear or burns.

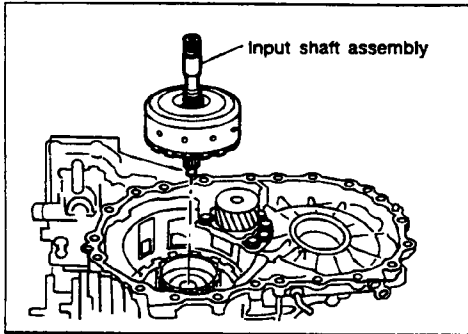

29. Remove input shaft assembly (high clutch), reverse clutch and front sun gear according to the following procedures.
- a. Remove input shaft assembly (high clutch) with reverse clutch.

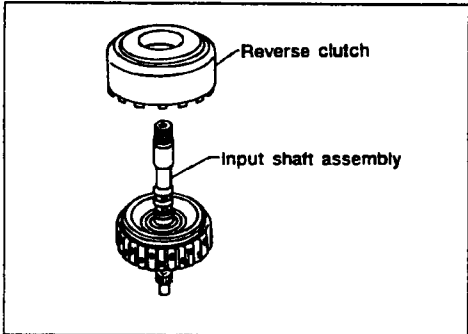

- b. Remove input shaft assembly (high clutch) from reverse clutch.

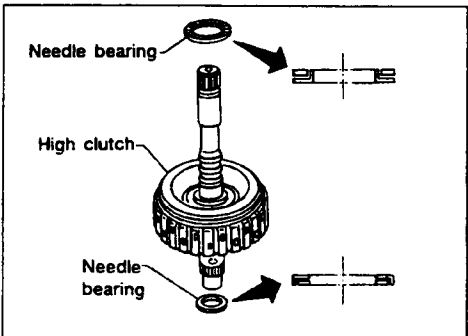

- c. Remove needle bearings from high clutch drum and check for damage or wear.

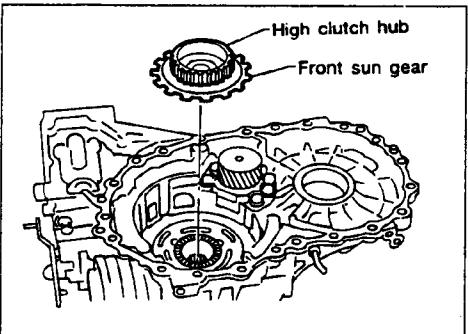

- d. Remove high clutch hub and front sun gear from transmission case.

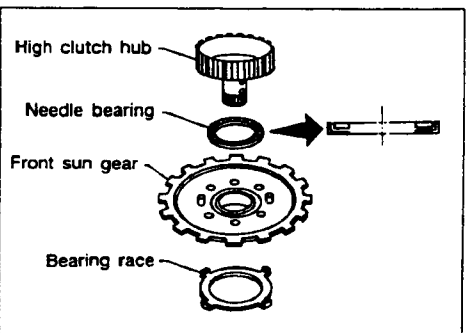

- e. Remove front sun gear and needle bearing from high clutch hub and check for damage or wear.
- f. Remove bearing race from front sun gear and check for damage or wear.



## Service Information RE4FO4A

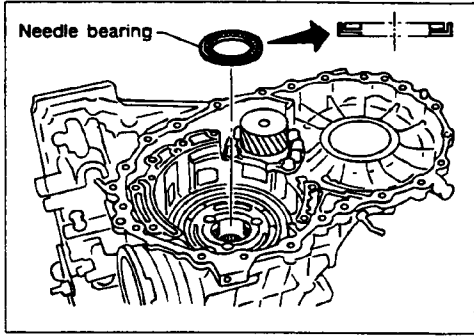

30. Remove needle bearing from transmission case and check for damage or wear.

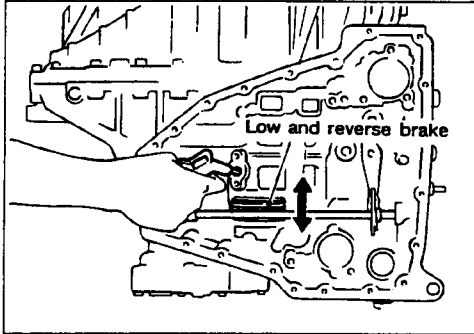

31. Apply compressed air and check to see that low and reverse brake operates.

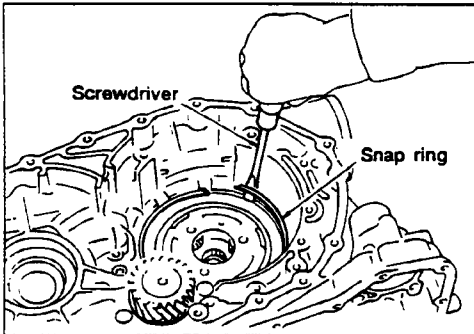

32. Remove low one-way clutch and front planetary carrier assembly according to the following procedures.  
a. Remove snap ring with flat-bladed screwdriver.

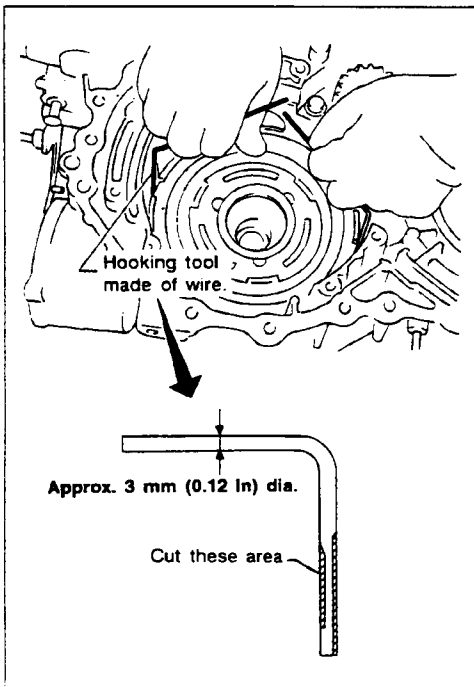

b. Remove low one way clutch with a hook made of wire.

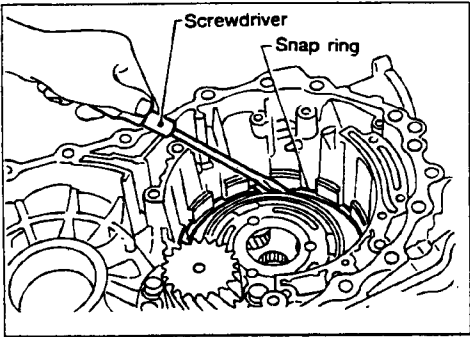

c. Remove snap ring with flat-bladed screwdriver.

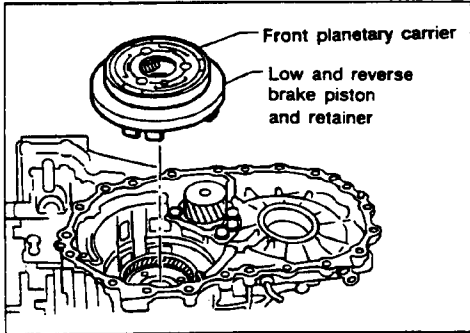

d. Remove front planetary carrier with low and reverse brake piston and retainer.

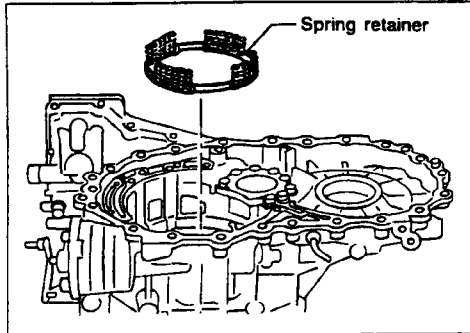

e. Remove low and reverse brake spring retainer.  
 ● Do not remove return springs from spring retainer.

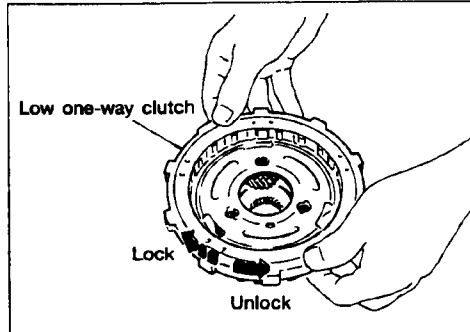

f. Check that low one-way clutch rotates in the direction of the arrow and locks in the opposite direction.

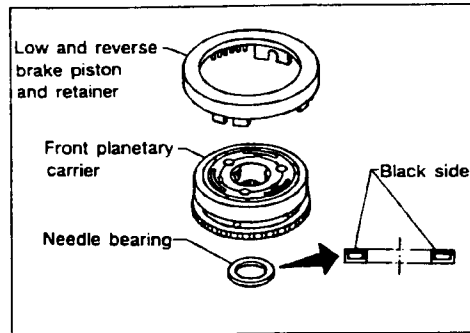

g. Remove needle bearing, low and reverse brake piston and retainer from front planetary carrier.

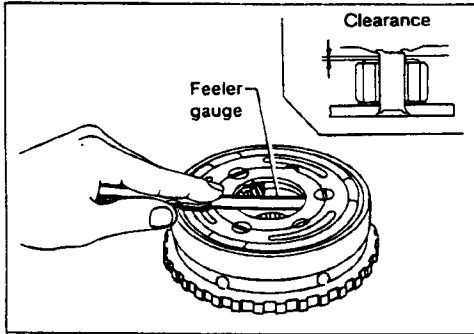

- h. Check front planetary carrier, low one-way clutch and needle bearing for damage or wear.
- i. Check clearance between planetary gears and planetary carrier with feeler gauge.

**Standard clearance:**

**0.20 - 0.70 mm (0.0079 - 0.0276 in)**

**Allowable limit:**

**0.80 mm (0.0315 in)**

Replace front planetary carrier if the clearance exceeds allowable limit.

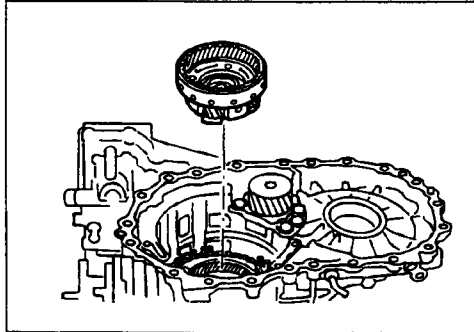

- 33. Remove rear planetary carrier assembly and rear sun gear according to the following procedures.

- a. Remove rear planetary carrier assembly from transmission case.

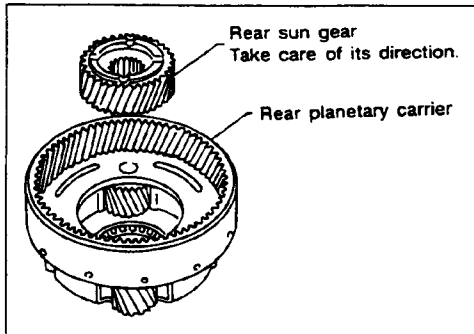

- b. Remove rear sun gear from rear planetary carrier.

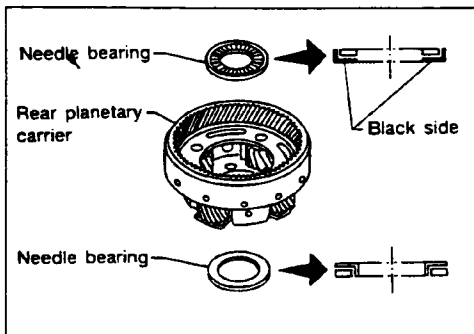

- c. Remove needle bearings from rear planetary carrier assembly.

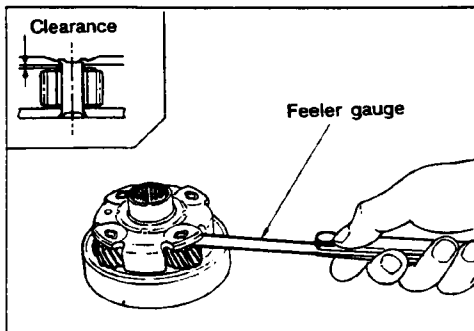

- d. Check rear planetary carrier, rear sun gear and needle bearings for damage or wear.
- e. Check clearance between pinion washer and rear planetary carrier with feeler gauge.

**Standard clearance:**

**0.20 - 0.70 mm (0.0079 - 0.0276 in)**

**Allowable limit:**

**0.80 mm (0.0315 in)**

Replace rear planetary carrier if the clearance exceeds allowable limit.



## Service Information RE4FO4A

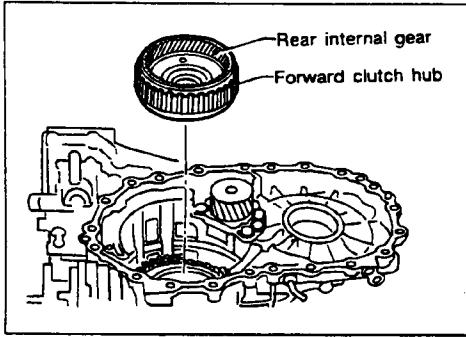

34. Remove rear internal gear and forward clutch hub from transmission case.

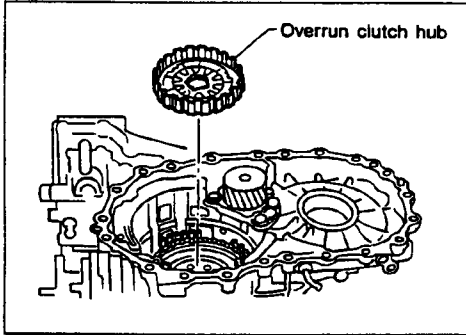

35. Remove overrun clutch hub from transmission case.

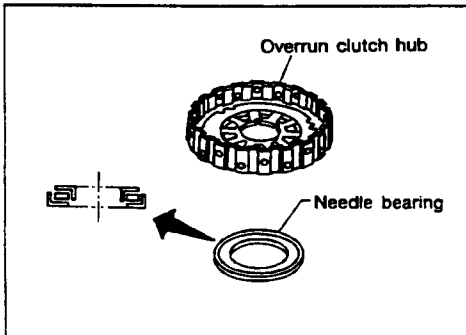

36. Remove needle bearing from overrun clutch hub and check for damage or wear.

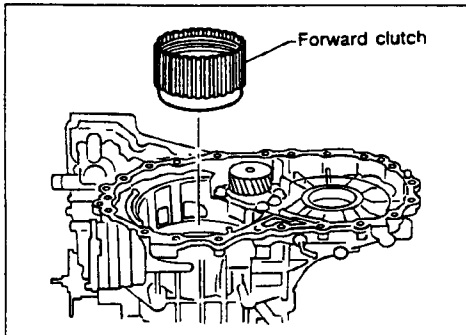

37. Remove forward clutch assembly from transmission case.

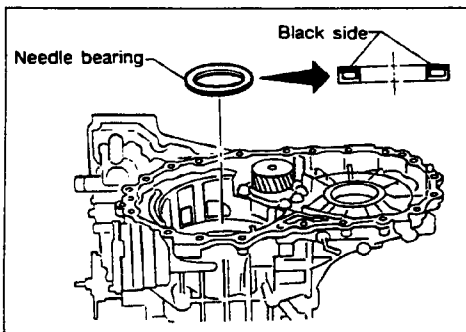

38. Remove needle bearing from transmission case.

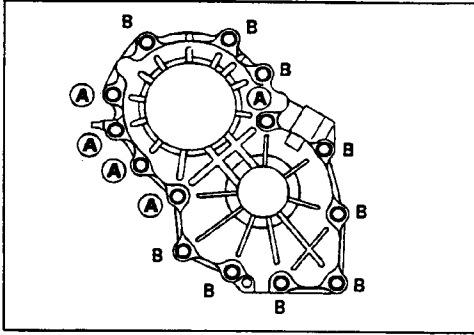

39. Remove output shaft assembly according to the following procedures.

a. Remove side cover bolts.

- Do not mix bolts (A) and (B).
- Always replace bolts (A) as they are self-sealing bolts.

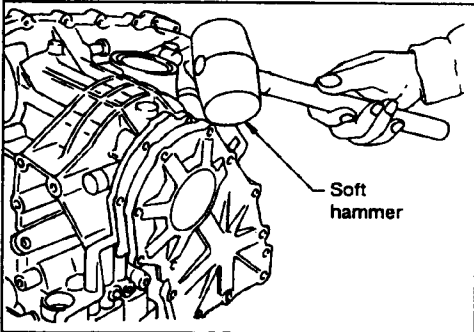

b. Remove side cover by lightly tapping it with a soft hammer.

- Be careful not to drop output shaft assembly as output shaft assembly may be removed together with side cover.

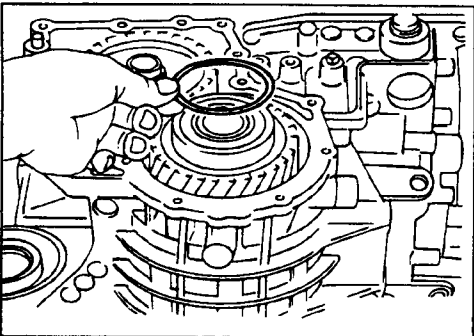

c. Remove adjusting shim.

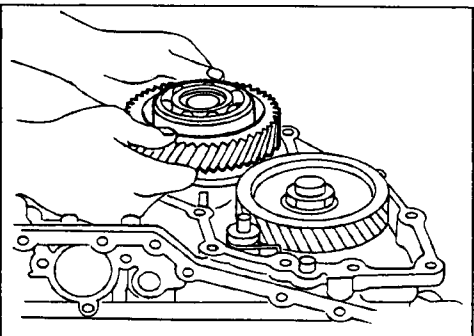

d. Remove output shaft assembly.

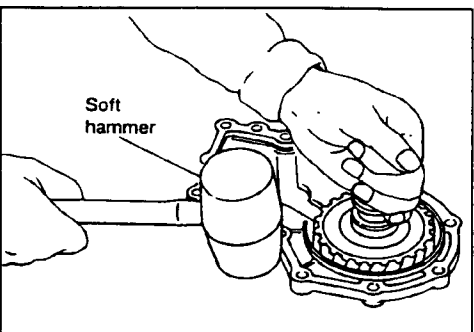

- If output shaft assembly was removed together with side cover, remove side cover by tapping it lightly with a soft hammer.

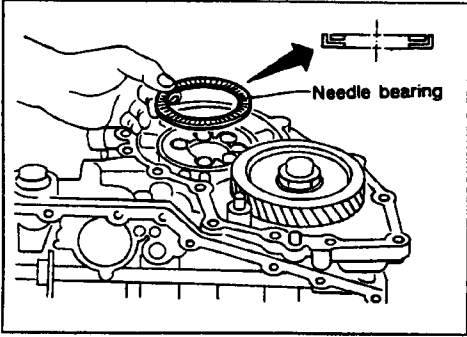

e. Remove needle bearing.

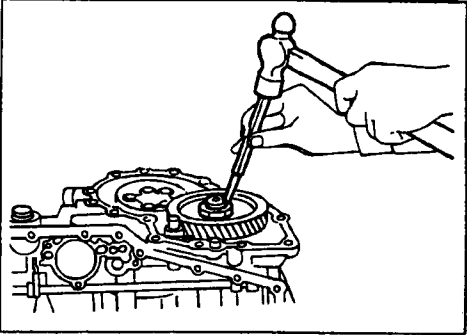

40. Disassemble reduction gear according to the following procedures.
- a. Set manual lever to position "P" to fix idler gear.
  - b. Unlock idler gear lock nut using a pin punch.

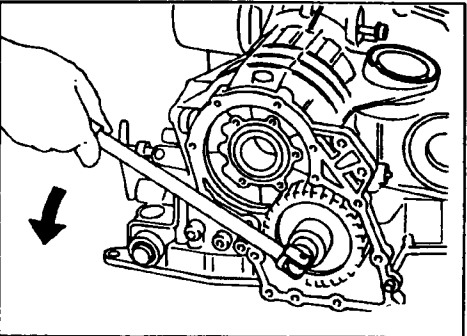

- c. Remove idler gear lock nut.
- Do not reuse idler gear lock nut.

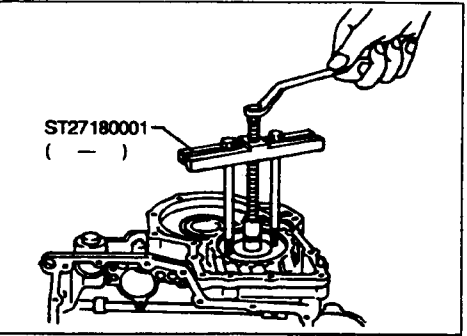

d. Remove idler gear with puller.

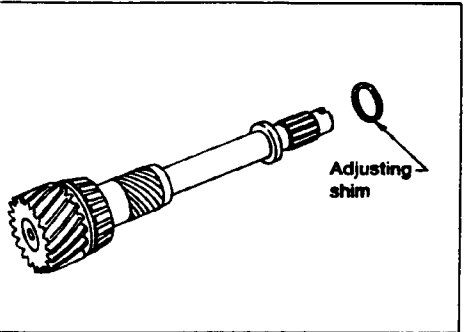

- e. Remove reduction gear.
- f. Remove adjusting shim from reduction gear.





## Service Information RE4FO4A

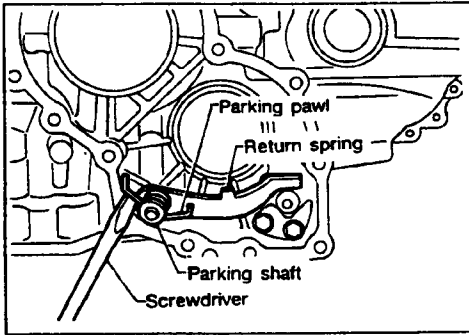

41. Remove return spring from parking shaft with screwdriver.
42. Draw out parking shaft and remove parking pawl from transmission case.
43. Check parking pawl and shaft for damage or wear.

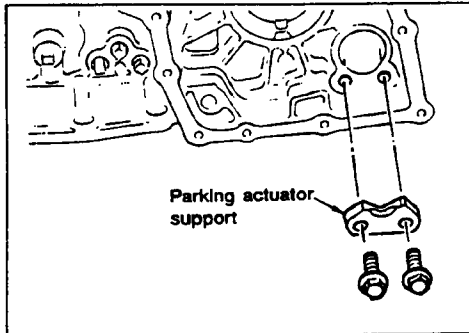

44. Remove parking actuator support from transmission case.
45. Check parking actuator support for damage or wear.

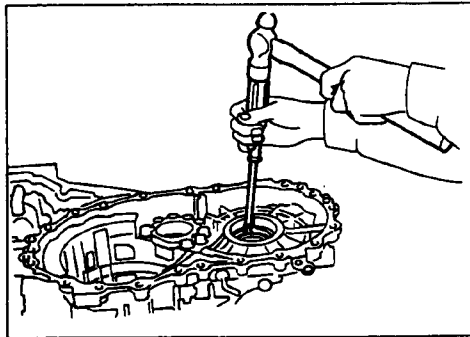

46. Remove side oil seal with screwdriver from transmission case.

## Manual Shaft

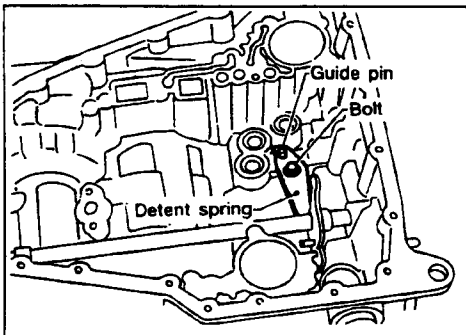
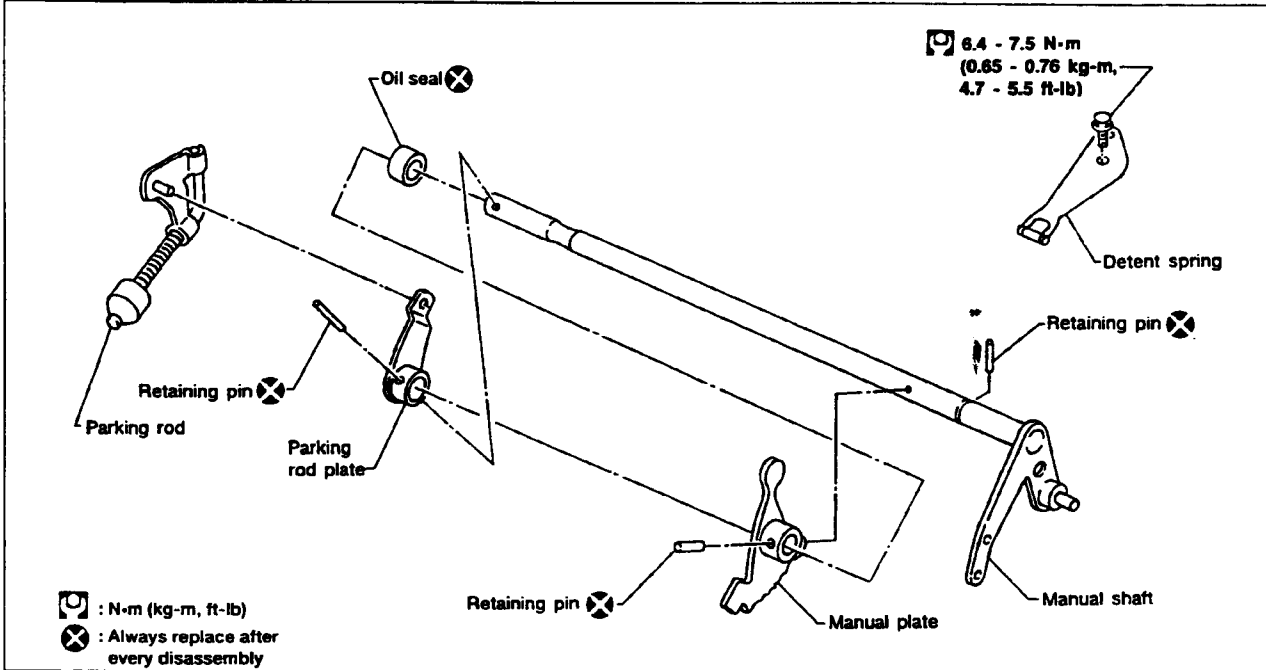

### REMOVAL

1. Remove detent spring from transmission case.

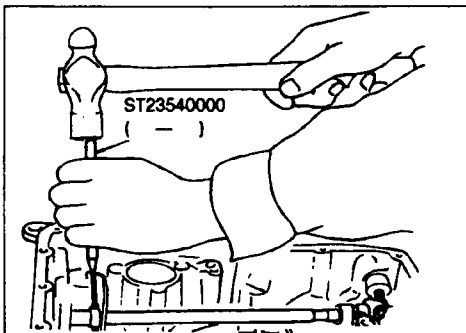

2. Drive out manual plate retaining pin.

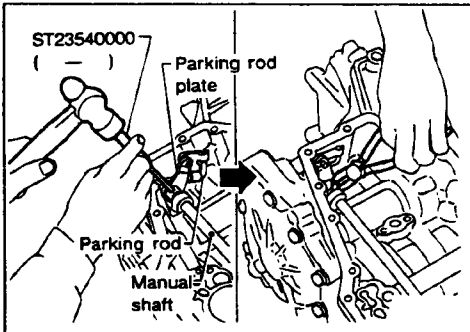

3. Drive and pull out parking rod plate retaining pin.
4. Remove parking rod plate from manual shaft.
5. Draw out parking rod from transmission case.

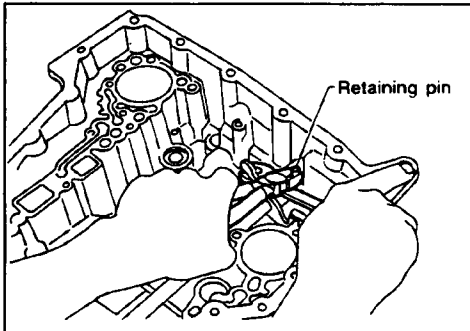

6. Pull out manual shaft retaining pin.
7. Remove manual shaft and manual plate from transmission case.

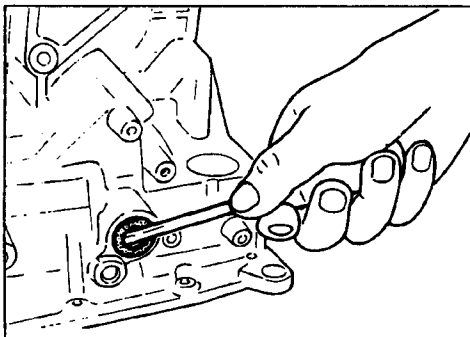

8. Remove manual shaft oil seal.

### INSPECTION

- Check component parts for wear or damage. Replace if necessary.

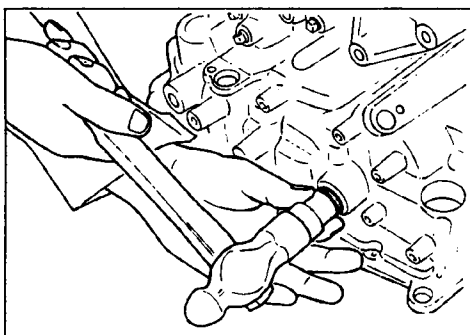

### INSTALLATION

1. Install manual shaft oil seal.
- Apply ATF to outer surface of oil seal.

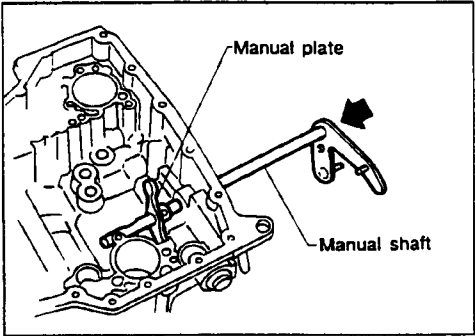

2. Install manual shaft and manual plate.

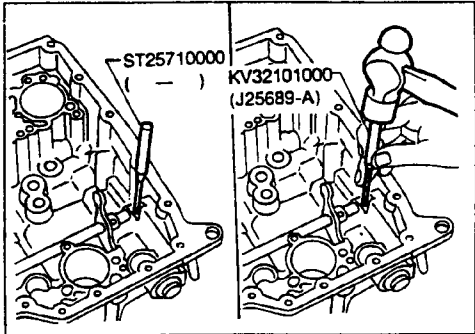

3. Align groove of manual shaft and hole of transmission case.  
4. Install manual shaft retaining pin up to bottom of hole.

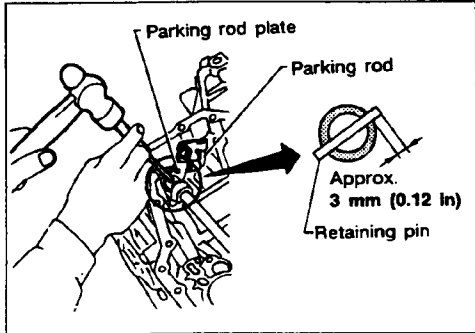

5. Install parking rod to parking rod plate.  
6. Set parking rod assembly onto manual shaft and drive retaining pin.  
**Both ends of pin should protrude.**

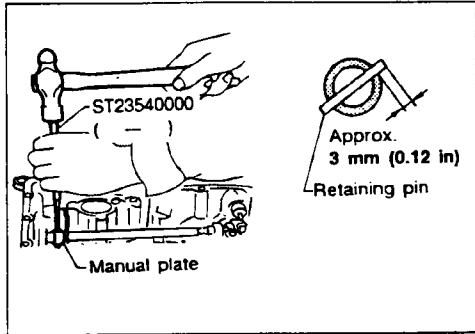

7. Drive manual plate retaining pin.  
**Both ends of pin should protrude.**

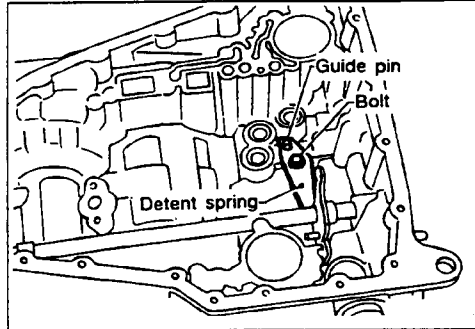

8. Install detent spring.

### Oil Pump

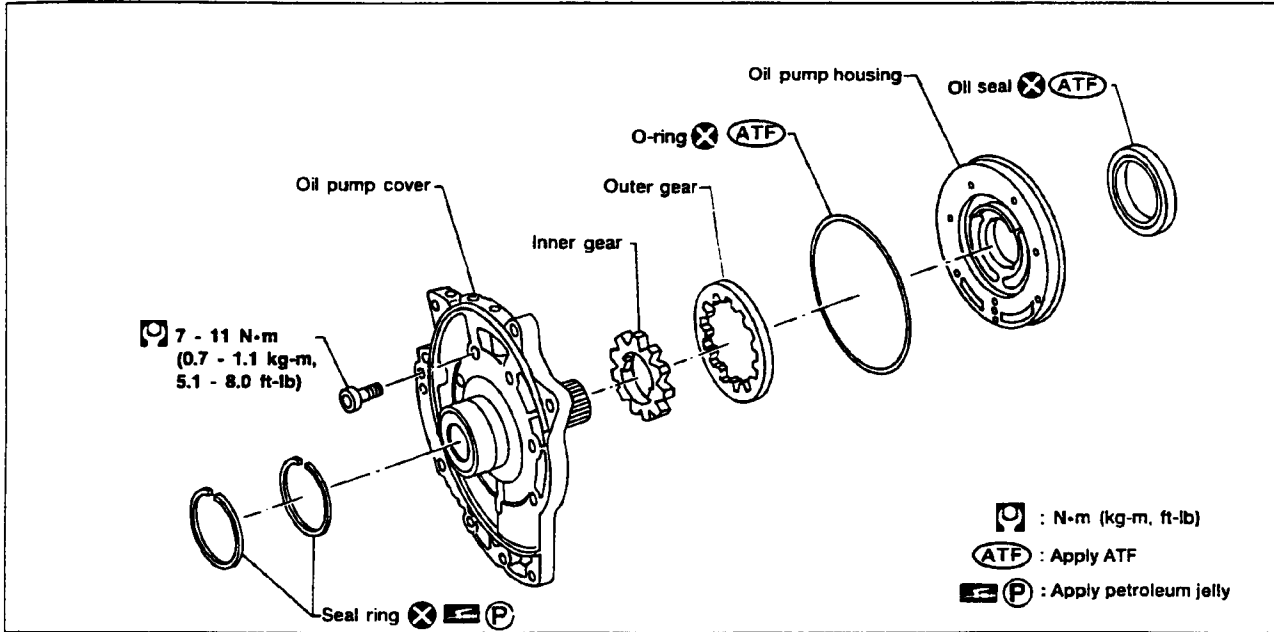

#### DISASSEMBLY

1. Remove seal rings by undoing hooks.

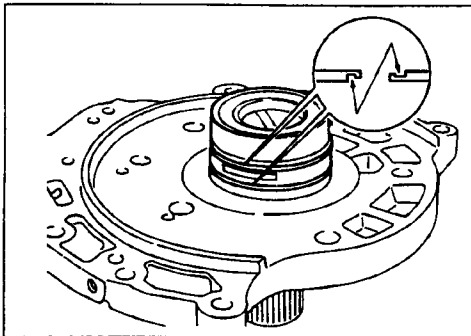

2. Loosen bolts in a crisscross pattern and remove oil pump cover.

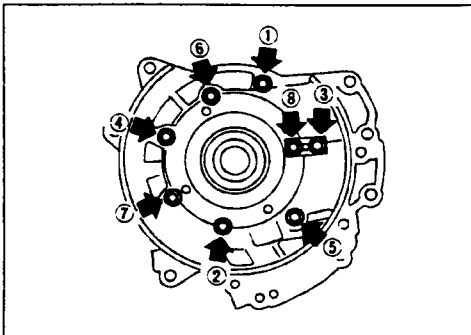

3. Remove inner and outer gear from oil pump housing.

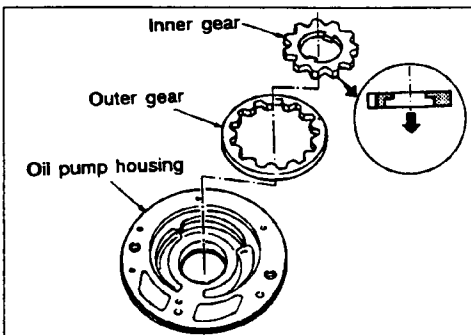

### Oil Pump (Cont'd)

4. Remove O-ring from oil pump housing.

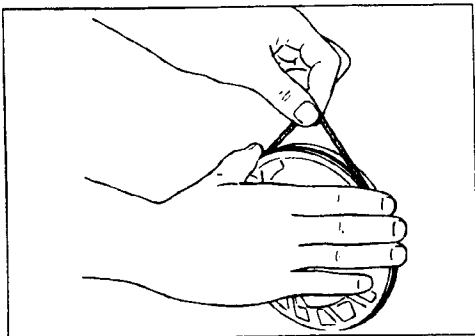

5. Remove oil pump housing oil seal.

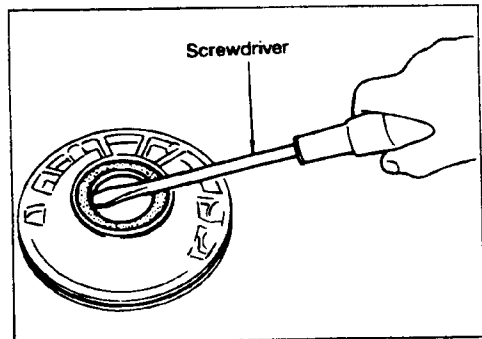

### INSPECTION

**Oil pump housing, oil pump cover, inner gear and outer gear**

- Check for wear or damage.

### Side clearance

- Measure side clearance between end of oil pump housing and inner and outer gears in at least four places along their circumferences. Maximum measured values should be within specified ranges.

**Standard clearance:**

**0.030 - 0.050 mm (0.0012 - 0.0020 in)**

- If clearance is less than standard, select inner and outer gear as a set so that clearance is within specifications.

**Inner and outer gear:**

**Refer to SDS**

- If clearance is more than standard, replace whole oil pump assembly except oil pump cover.

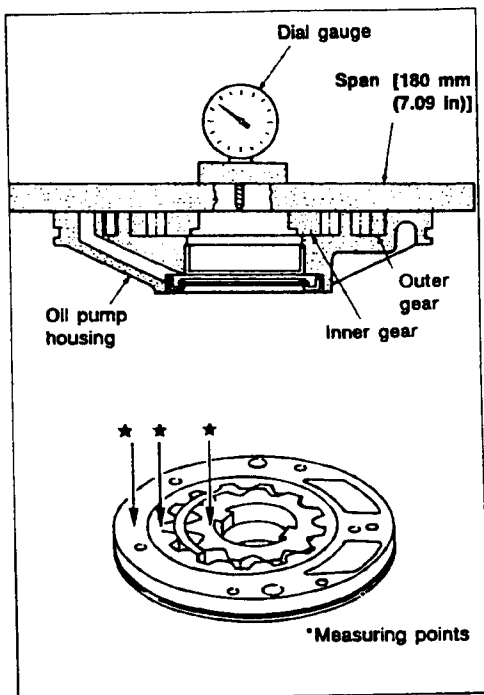



## Service Information RE4FO4A

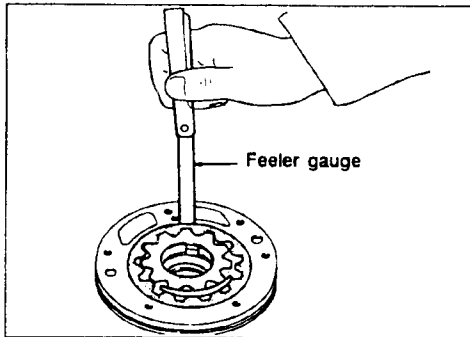

- Measure clearance between outer gear and oil pump housing.  
**Standard clearance:**  
0.111 - 0.181 mm (0.0044 - 0.0071 in)  
**Allowable limit:**  
0.181 mm (0.0071 in)
- If not within allowable limit, replace whole oil pump assembly except oil pump cover.

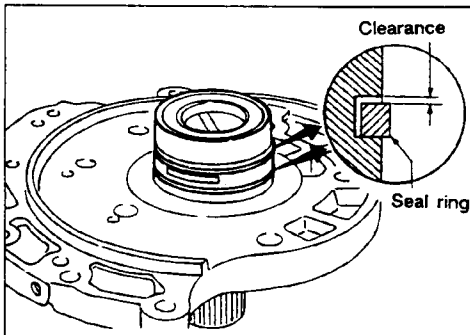

### Seal ring clearance

- Measure clearance between seal ring and ring groove.  
**Standard clearance:**  
0.036 - 0.176 mm (0.0014 - 0.0069 in)  
**Allowable limit:**  
0.176 mm (0.0069 in)
- If not within allowable limit, replace oil pump cover assembly.

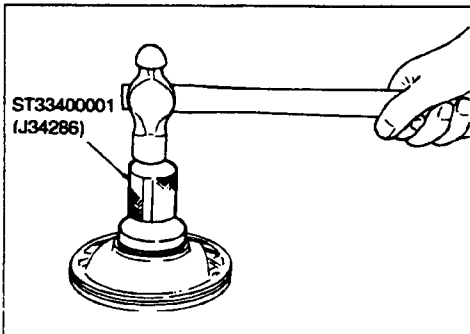

### ASSEMBLY

1. Install oil seal on oil pump housing.

### Oil Pump (Cont'd)

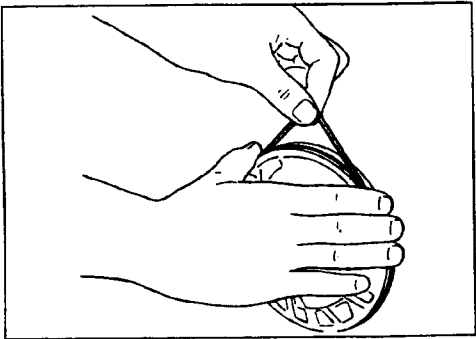

2. Install O-ring on oil pump housing.
  - **Apply ATF to O-ring.**

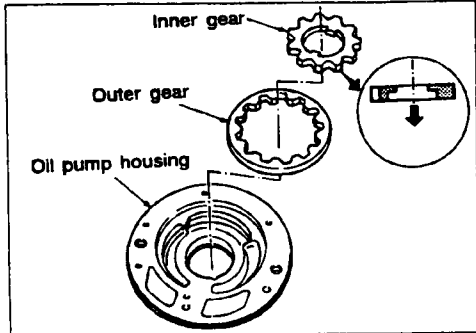

3. Install inner and outer gears on oil pump housing.
  - **Be careful of direction of inner gear.**

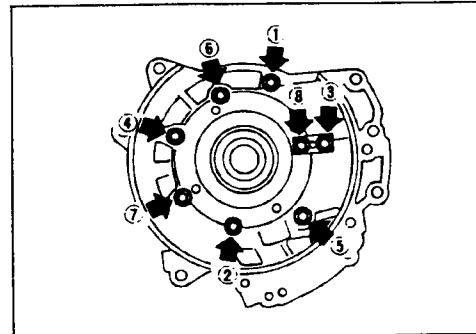

4. Install oil pump cover on oil pump housing.
  - a. Wrap masking tape around splines of oil pump cover assembly to protect seal. Position oil pump cover assembly on oil pump housing assembly, then remove masking tape.
  - b. Tighten bolts in a crisscross pattern.

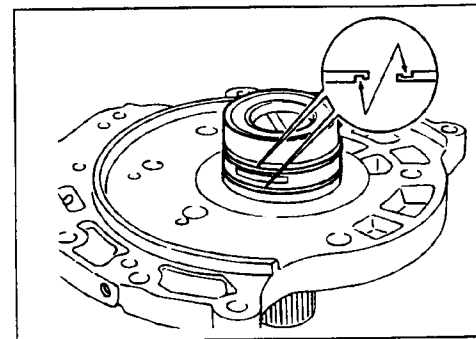

5. Install new seal rings carefully after packing ring groove with petroleum jelly and attach hooks.
  - **Do not spread gap of seal ring excessively while installing. The ring may be deformed.**





## Service Information RE4FO4A

### Control Valve Assembly

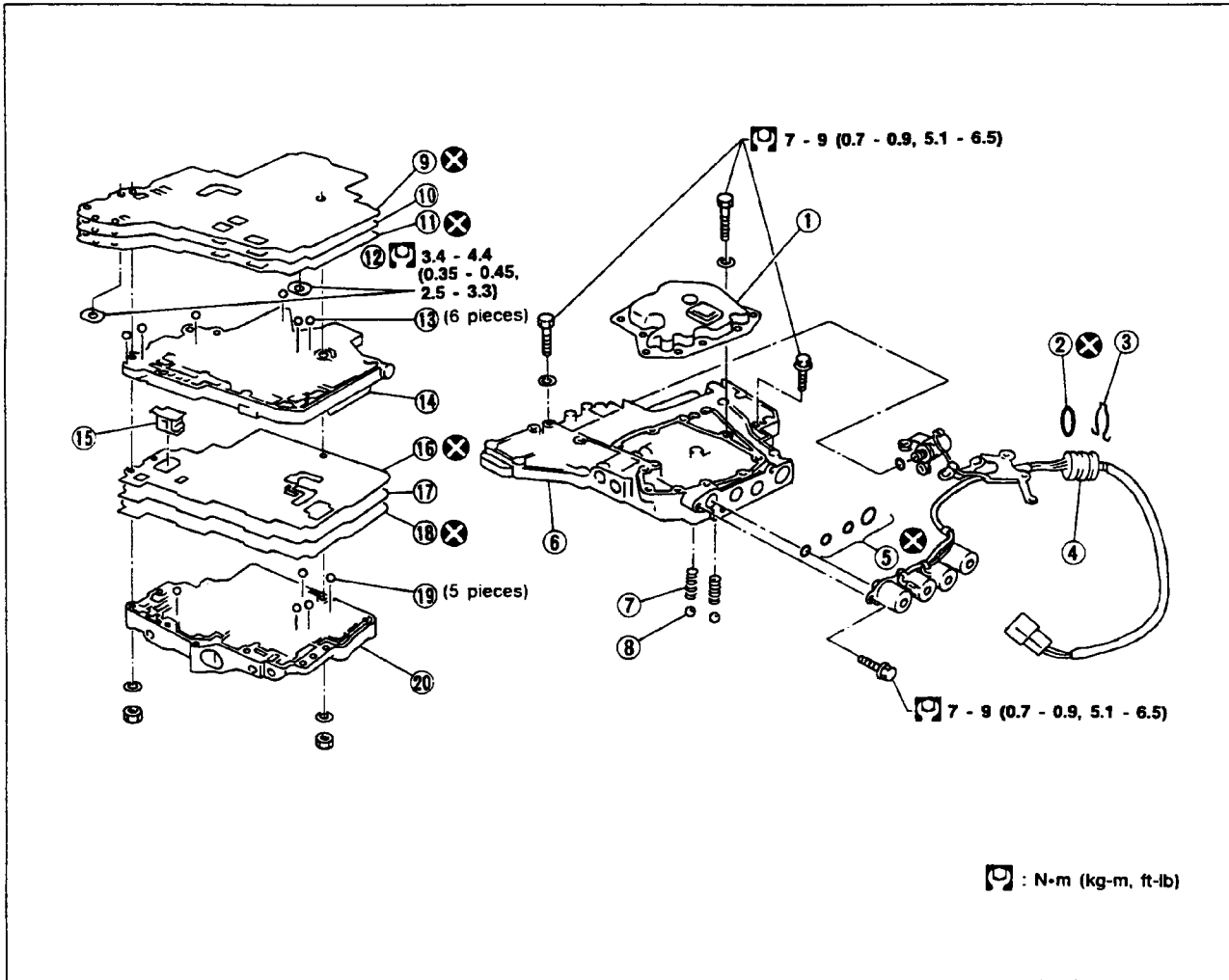

- |                                  |                                 |                                 |
|----------------------------------|---------------------------------|---------------------------------|
| ① Oil strainer                   | ⑧ Check ball                    | ⑮ Pilot filter                  |
| ② O-ring                         | ⑨ Lower separating gasket       | ⑯ Upper inter separating gasket |
| ③ Clamp                          | ⑩ Separating plate              | ⑰ Separating plate              |
| ④ Terminal body                  | ⑪ Lower inter separating gasket | ⑱ Upper separating gasket       |
| ⑤ O-rings                        | ⑫ Support plate                 | ⑲ Steel ball                    |
| ⑥ Control valve lower body       | ⑬ Steel ball                    | ⑳ Control valve upper body      |
| ⑦ Oil cooler relief valve spring | ⑭ Control valve inter body      |                                 |

#### DISASSEMBLY

Disassemble upper, inter and lower bodies.

**Bolt length, number and location:**

Bolt symbol	a	b	c	d	e	f
Bolt length "f" mm (in)	13.5 (0.531)	58.0 (2.283)	40.0 (1.575)	66.0 (2.598)	33.0 (1.299)	78.0 (3.071)
Number of bolts	6	3	6	11	2	2

f: Reamer bolt and nut.

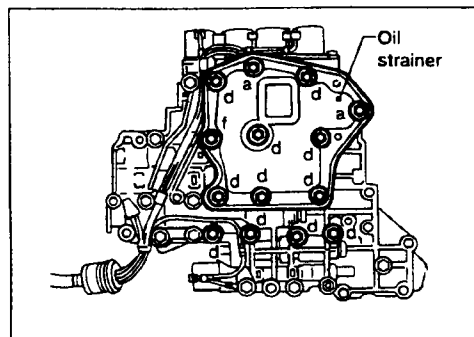
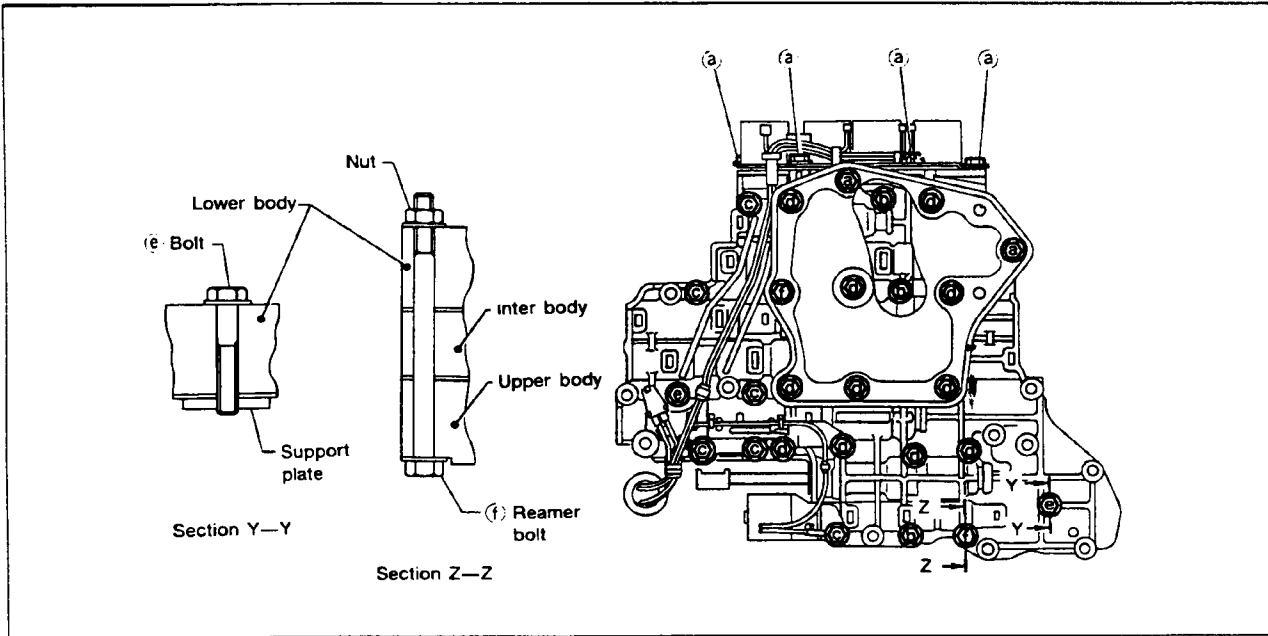

- a. Remove bolts (a), (d) and nut (f) and remove oil strainer from control valve assembly.

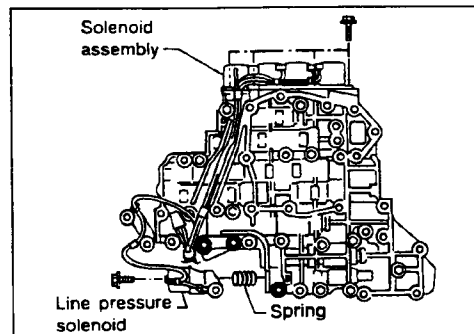

- b. Remove solenoid assembly and solenoid from control valve assembly.

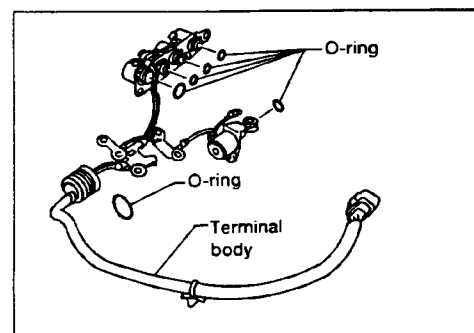

- c. Remove O-rings from solenoids and terminal body.

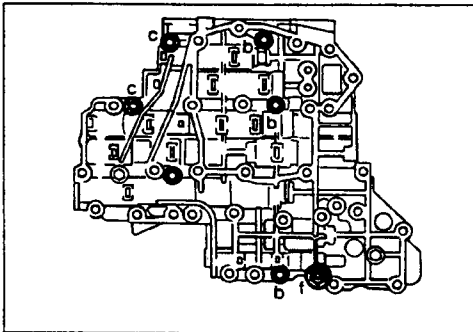

d. Place upper body facedown, and remove bolts (b), (c) and nut (f).

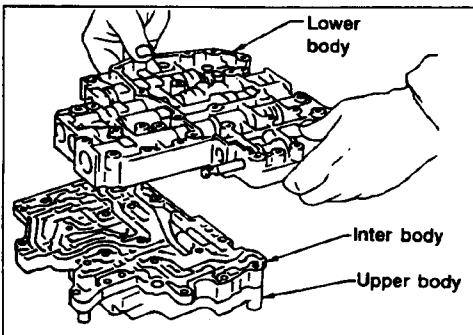

e. Remove inter body from lower body.

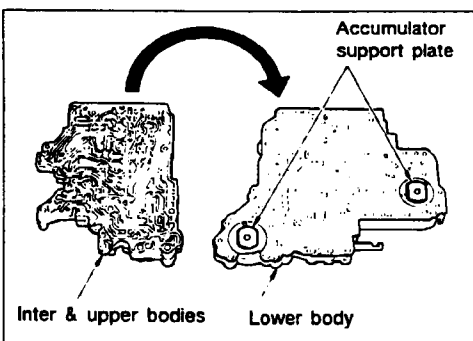

f. Turn over lower body, and remove accumulator support plate.

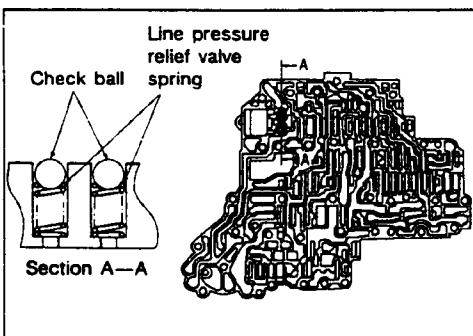

g. Remove bolts (e), separating plate and separating gasket from lower body.

h. Remove steel balls and relief valve springs from lower body.

● **Be careful not to lose steel balls and relief valve springs.**

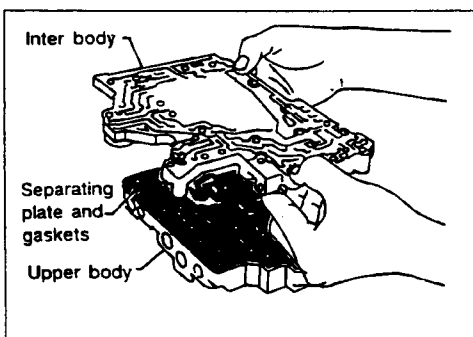

i. Remove inter body from upper body.

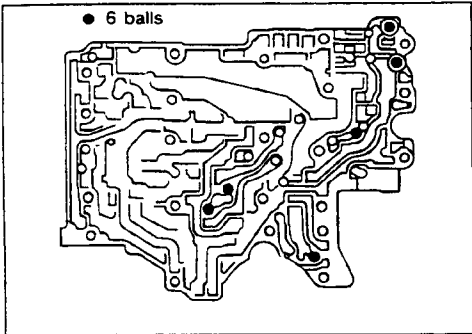

- j. Check to see that steel balls are properly positioned in inter body and then remove them from inter body.
- **Be careful not to lose steel balls.**

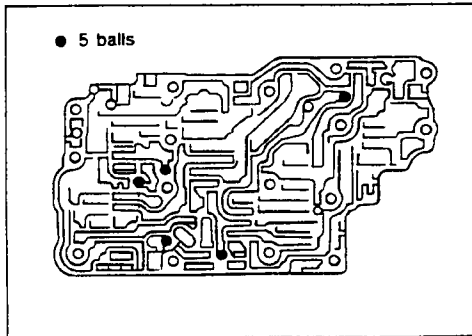

- k. Check to see that steel balls are properly positioned in upper body and then remove them from upper body.
- **Be careful not to lose steel balls.**

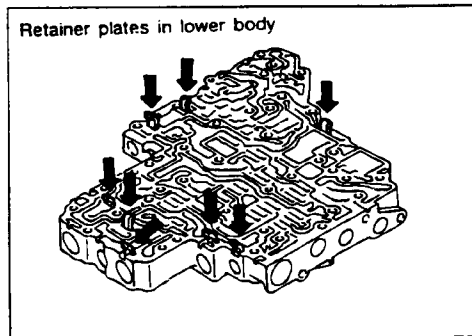

### INSPECTION

#### Lower and upper bodies

- Check to see that retainer plates are properly positioned in lower body.

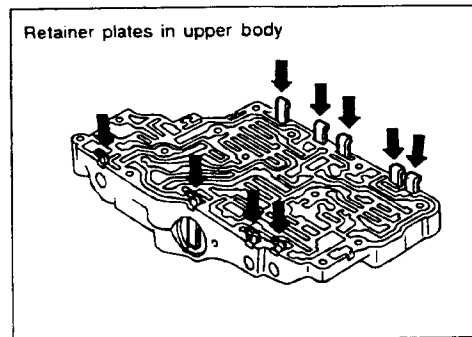

- Check to see that retainer plates are properly positioned in upper body.
- **Be careful not to lose these parts.**

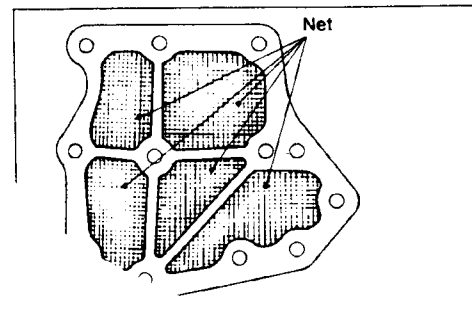

#### Oil strainer

- Check wire netting of oil strainer for damage.



**Service Information RE4F04A**

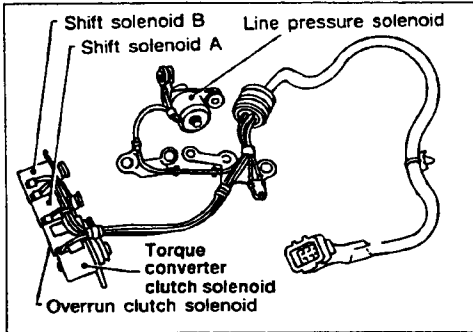

**Shift solenoid A and B, line pressure solenoid, torque converter clutch solenoid valve and overrun clutch solenoid.**

- Measure resistance — See “Solenoids and Fluid Temperature Sensor”. **Refer to page 10**

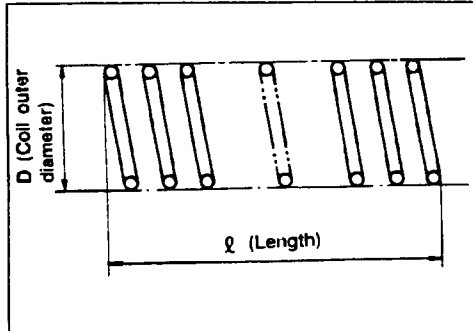

**Oil cooler relief valve spring.**

- Check springs for damage or deformation.
- Measure free length and outer diameter

**Inspection standard:**

Unit: mm (in)

Part No.	l	D	
31872-31X00	17.02 (0.6701)	8.0 (0.315)	

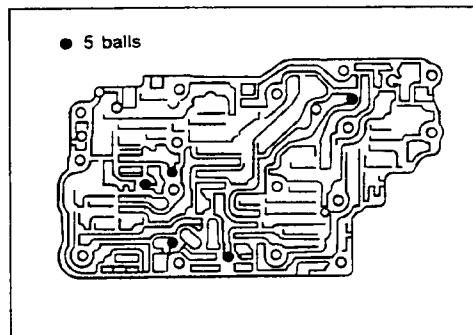

**ASSEMBLY**

1. Install upper, inter and lower body.
  - a. Place oil circuit of upper body face up. Install steel balls in their proper positions.

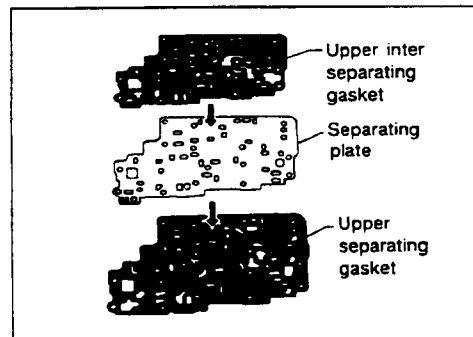

- b. Install upper separating gasket, upper inter separating gasket and upper separating plate in order shown in illustration.

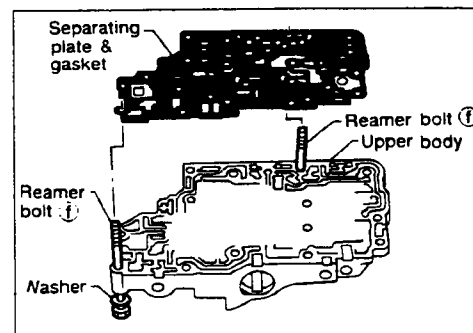

- c. Install reamer bolts (f) from bottom of upper body and install separating gaskets and separating plate as a set on upper body using reamer bolts as guides.

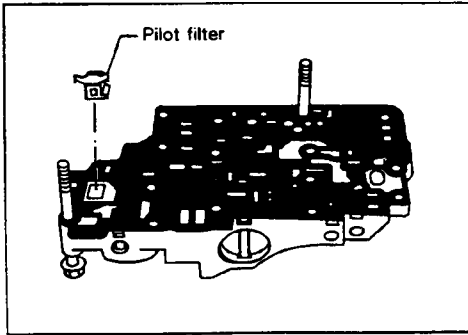

d. Install pilot filter.

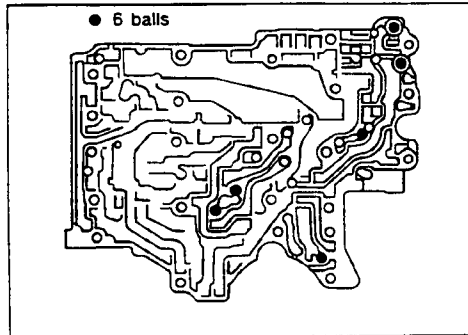

e. Place lower body as shown in illustration (side of inter body face up). Install steel balls in their proper positions.

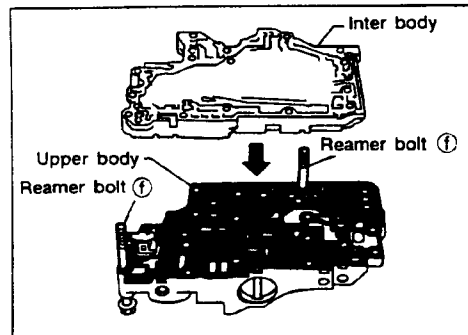

f. Install inter body on upper body using reamer bolts ① as guides.

● Be careful not to dislocate or drop steel balls.

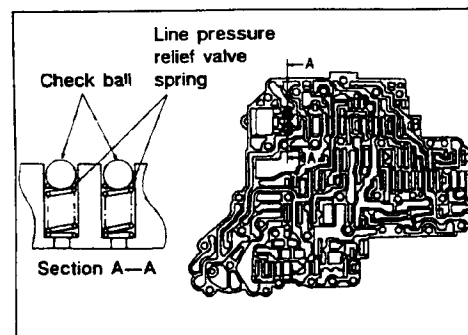

g. Install steel balls and relief valve springs in their proper positions in lower body.

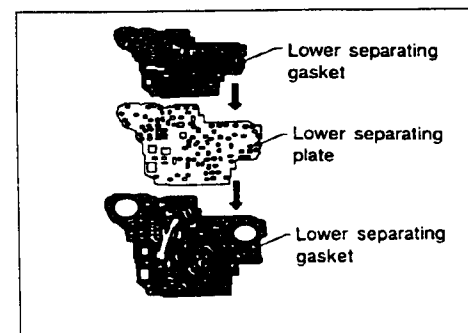

h. Install lower separating gasket, inter separating gasket and lower separating plate in order shown in illustration.

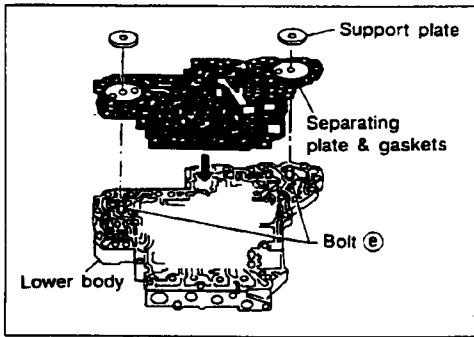

- i. Install bolts (e) from bottom of lower body and install separating gaskets and separating plate as a set on lower body using bolts (e) as guides.
- j. Temporarily install support plates on lower body.

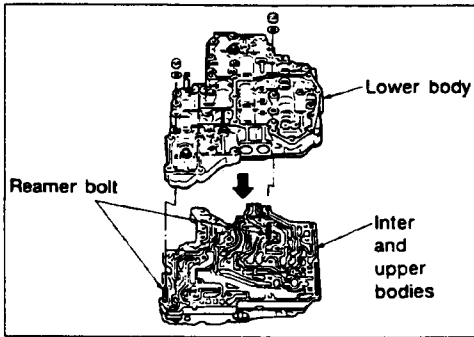

- k. Install lower body on inter body using reamer bolts (f) as guides and tighten reamer bolts (f) slightly.

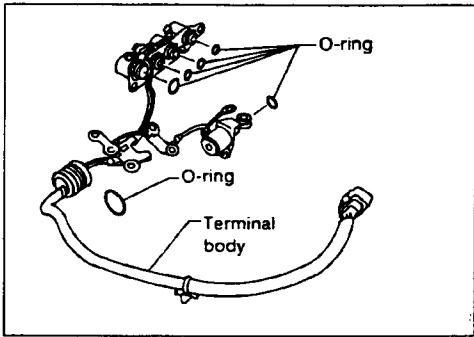

- 2. Install O-rings to solenoids and terminal body.
- Apply ATF to O-rings.

3. Install and tighten bolts.

**Bolt length, number and location:**

Bolt symbol	a	b	c	d	e	f
Bolt length "r" mm (in)	13.5 (0.531)	58.0 (2.283)	40.0 (1.575)	66.0 (2.598)	33.0 (1.299)	78.0 (3.071)
Number of bolts	6	3	6	11	2	2

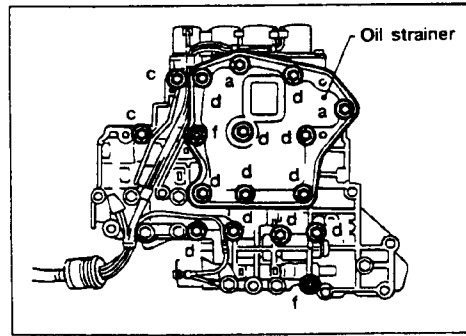
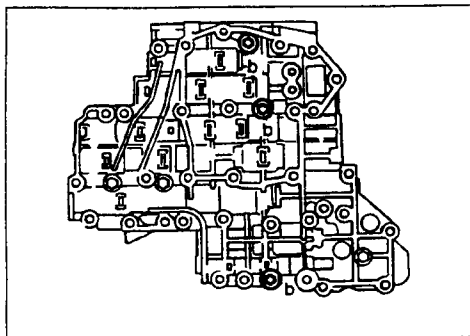
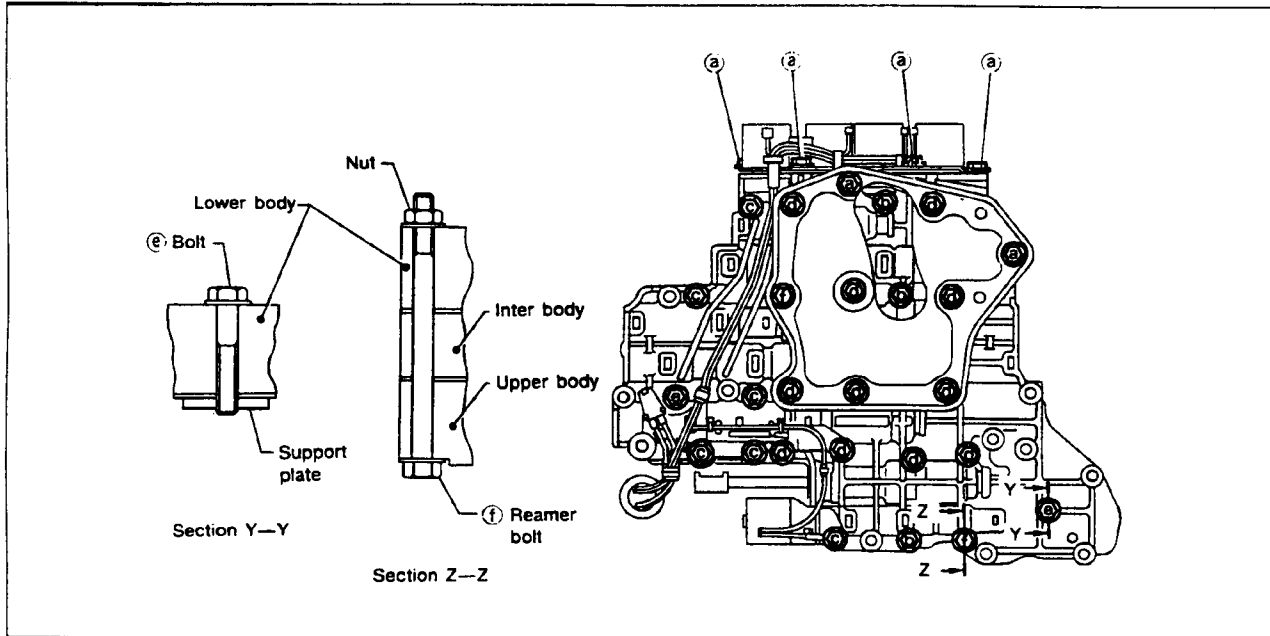

a. Install and tighten bolts (b) to specified torque.

f. Set oil strainer, then tighten bolts (a), (c), (d) and nuts (f) to specified torque.

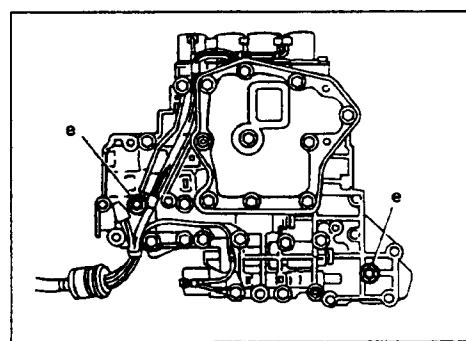
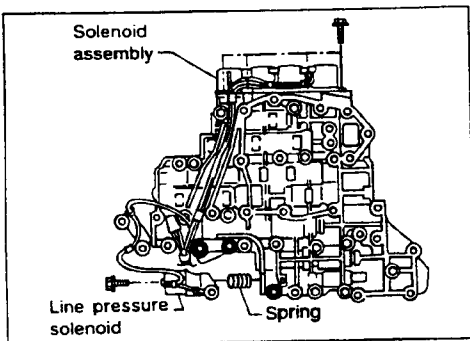

b. Install solenoid assembly and line pressure solenoid to lower body.

g. Tighten bolts (e) (2 pieces) to specified torque.



### Control Valve Upper Body

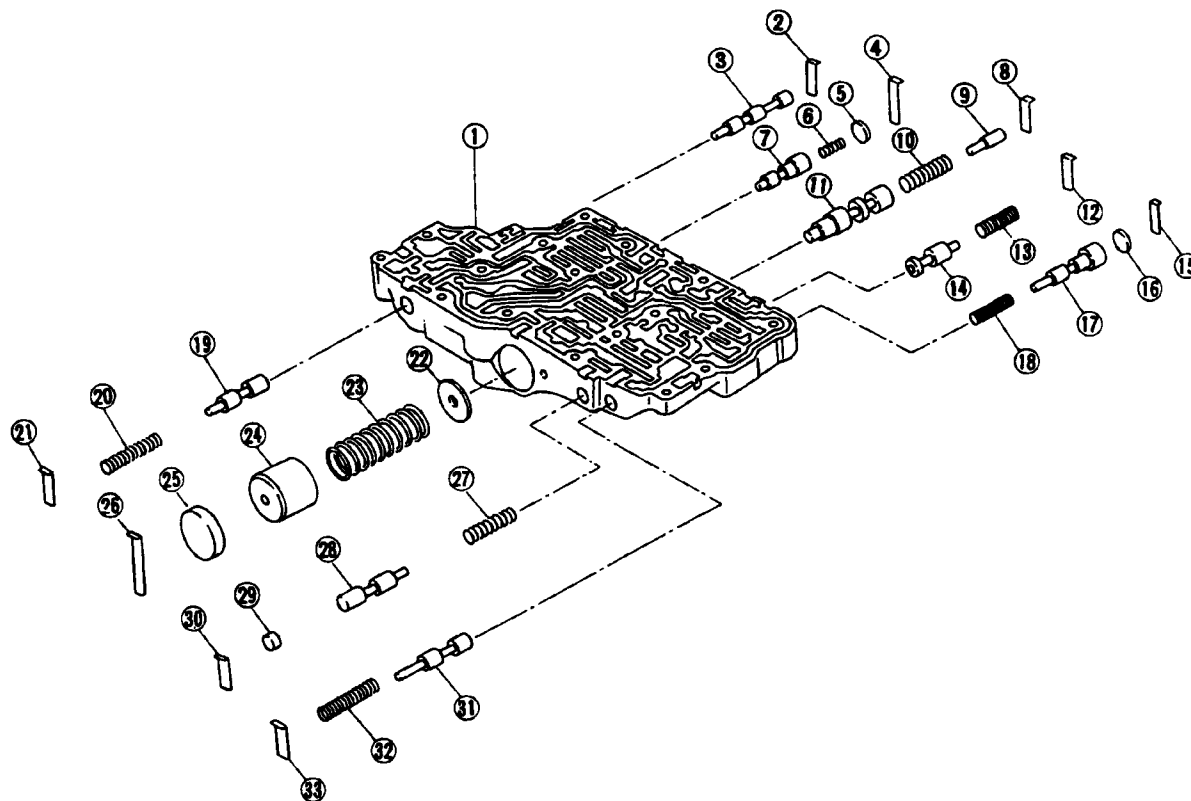

- ① Upper body
- ② Retainer plate
- ③ Valve-shaped plug
- ④ Retainer plate
- ⑤ Plug
- ⑥ Return spring
- ⑦ 1-2 accumulator valve
- ⑧ Retainer plate
- ⑨ Plug
- ⑩ Return spring
- ⑪ Lock-up control valve
- ⑫ Retainer plate

- ⑬ Return spring
- ⑭ Torque converter relief valve
- ⑮ Retainer plate
- ⑯ Plug
- ⑰ Overrun clutch reducing valve
- ⑱ Return spring
- ⑲ Pilot valve
- ⑳ Return spring
- ㉑ Retainer plate
- ㉒ 1-2 accumulator retainer plate
- ㉓ Return spring
- ㉔ 1-2 accumulator piston

- ㉕ Plug
- ㉖ Retainer plate
- ㉗ Return spring
- ㉘ 1st reducing valve
- ㉙ Plug
- ㉚ Retainer plate
- ㉛ 2-3 timing valve
- ㉜ Return spring
- ㉝ Retainer plate



## Service Information RE4FO4A

### Control Valve Upper Body

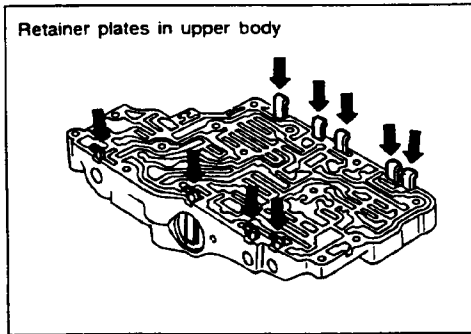

#### DISASSEMBLY

1. Remove valves at retainer plates.
  - Do not use a magnetic "hand".

- a. Use a screwdriver to pry out retainer plates.

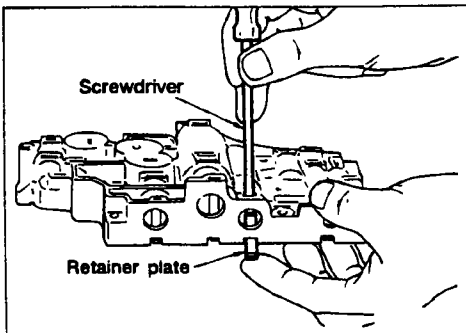

- b. Remove retainer plates while holding spring, plugs or sleeves.
  - Remove plugs slowly to prevent internal parts from jumping out.

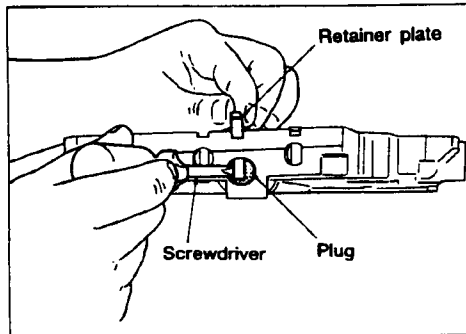

- c. Place mating surface of valve body face down, and remove internal parts.
  - If a valve is hard to remove, place valve body face down and lightly tap it with a soft hammer.
  - Be careful not to drop or damage valves and sleeves.

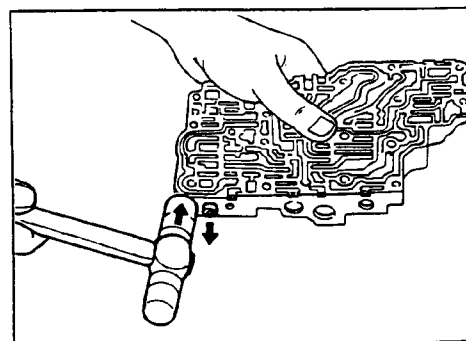

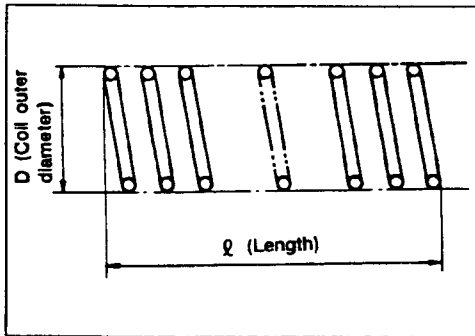

### INSPECTION

#### Valve spring

- Measure free length and outer diameter of each valve spring. Also check for damage or deformation.
- Numbers of each valve spring listed in table below are the same as those in the figure on page **Page 49**

#### Inspection standard

Unit: mm (in)

	Parts	Part No.	l	D
⑳	Pilot valve spring	31742 80x14	36.0 (1.417)	8.1 (0.319)
㉑	1-2 accumulator valve spring	31742 80x10	20.5 (0.807)	7.0 (0.276)
㉒	1-2 accumulator piston spring	31742 80x12	52.0 (2.047)	19.6 (0.772)
㉓	1st reducing valve spring	31742 80x05	27.0 (1.063)	7.0 (0.276)
㉔	2-3 timing valve	31742 80x18	30.5 (1.201)	6.6 (0.260)
㉕	Overrun clutch reducing valve spring	31742 80x15	37.5 (1.476)	6.9 (0.272)
㉖	Torque converter relief valve spring	31742 80x07	31.0 (1.220)	9.0 (0.354)
㉗	Lock-up control valve	31742 80x17	39.5 (1.555)	11.0 (0.433)

- Replace valve springs if deformed or fatigued.

#### Control valves

- Check sliding surfaces of valves, sleeves and plugs.

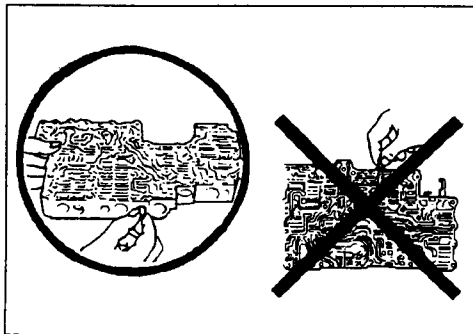

#### ASSEMBLY

- Lay control valve body down when installing valves. Do not stand the control valve body upright.

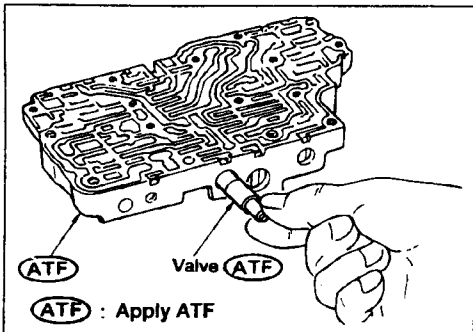

1. Lubricate the control valve body and all valves with ATF. Install control valves by sliding them carefully into their bores.
- Be careful not to scratch or damage valve body.

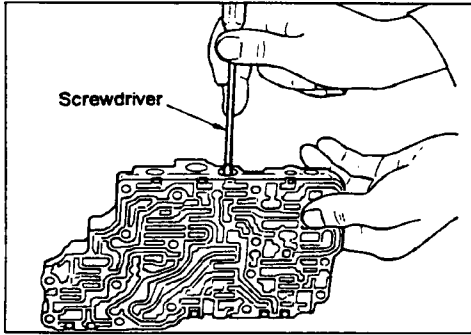

- Wrap a small screwdriver with vinyl tape and use it to insert the valves into their proper positions.

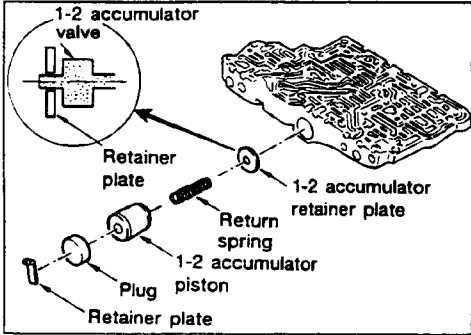

**1-2 accumulator valve**

- Install 1-2 accumulator valve and then align 1-2 accumulator retainer plate with 1-2 accumulator valve from opposite side of control valve body.
- Install return spring, 1-2 accumulator piston and plug.

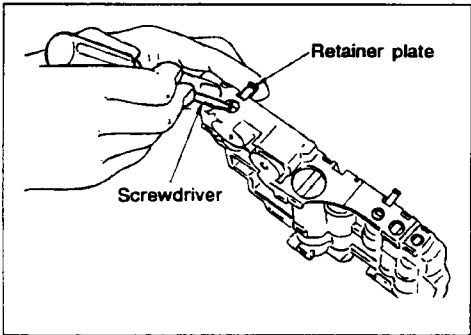

2. Install retainer plates
  - Install retainer plate while pushing plug or return spring.

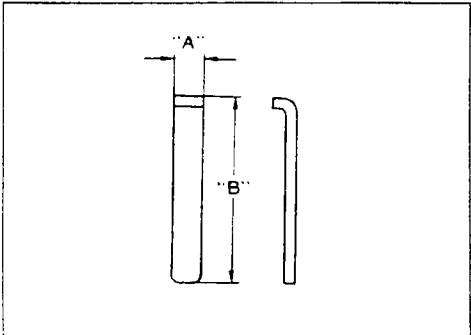

**Retainer plate**

Unit: mm (in)		
Name of control valve	Length A	Length B
Pilot valve	6.0 (0.236)	21.5 (0.846)
1-2 accumulator valve		38.5 (1.516)
1-2 accumulator piston valve		21.5 (0.846)
1st reducing valve		24.0 (0.945)
2-3 timing valve		21.5 (0.846)
Overrun clutch reducing valve		28.0 (1.102)
Torque converter relief valve		28.0 (1.102)
Lock-up control valve		28.0 (1.102)
Sequence valve		

- Install proper retainer plates.

### Control Valve Lower Body

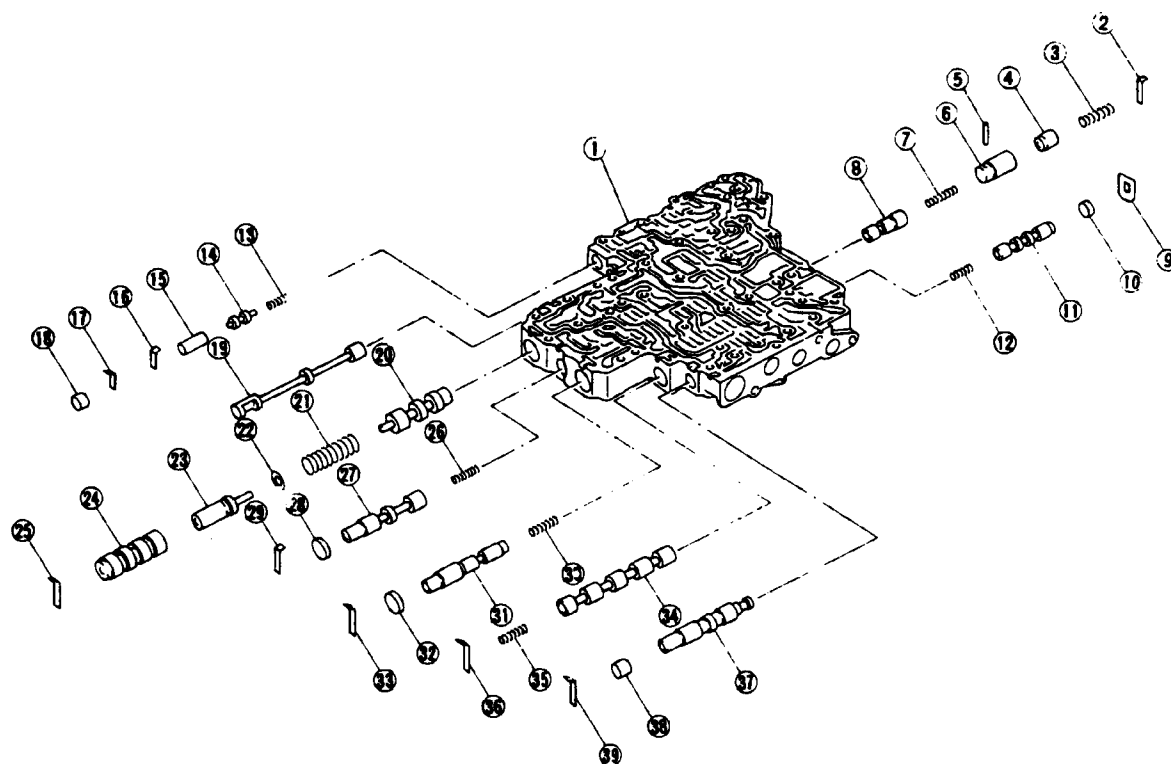

- |  |  |   |
|--|--|---|
| <ul style="list-style-type: none"> <li>① Lower body</li> <li>② Retainer plate</li> <li>③ Return spring</li> <li>④ Piston</li> <li>⑤ Parallel pin</li> <li>⑥ Sleeve</li> <li>⑦ Return spring</li> <li>⑧ Pressure modifier valve</li> <li>⑨ Retainer plate</li> <li>⑩ Plug</li> <li>⑪ Shift valve B</li> <li>⑫ Return spring</li> <li>⑬ Return spring</li> </ul> | <ul style="list-style-type: none"> <li>⑭ Accumulator shift valve</li> <li>⑮ Plug</li> <li>⑯ Retainer plate</li> <li>⑰ Retainer plate</li> <li>⑱ Plug</li> <li>⑲ Manual valve</li> <li>⑳ Pressure regulator valve</li> <li>㉑ Return spring</li> <li>㉒ Spring seat</li> <li>㉓ Plug</li> <li>㉔ Sleeve</li> <li>㉕ Retainer plate</li> <li>㉖ Return spring</li> </ul> | <ul style="list-style-type: none"> <li>㉗ Overrun clutch control valve</li> <li>㉘ Plug</li> <li>㉙ Retainer plate</li> <li>㉚ Return spring</li> <li>㉛ Accumulator control valve</li> <li>㉜ Plug</li> <li>㉝ Retainer plate</li> <li>㉞ Shift valve A</li> <li>㉟ Return spring</li> <li>㊱ Retainer plate</li> <li>㊲ Valve-shaped plug</li> <li>㊳ Plug</li> <li>㊴ Retainer plate</li> </ul> |
|--|--|---|

Retainer plates in lower body

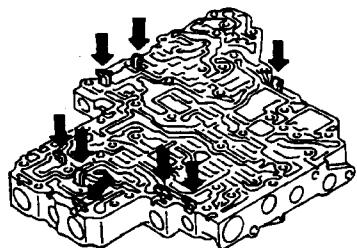

### DISASSEMBLY

Remove valves at retainer plate.

For removal procedures, see "DISASSEMBLY" of Control Valve Upper Body. **Refer to Page 50**

### INSPECTION

#### Valve springs

- Check each valve spring for damage or deformation. Also measure free length and outer diameter.
- Numbers for each valve spring listed in the table below are the same as those in the figure on **page 53**

D (Coil outer diameter)

ℓ (Length)

### Inspection standard

Unit: mm (in)

	Parts	Part No.	ℓ	D
⑬	Accumulator shift valve spring	31736 01X00	23.0 (0.906)	6.65 (0.2618)
⑳	Pressure regulator valve spring	31742 80X13	45.0 (1.772)	15.0 (0.591)
㉔	Overrun clutch control valve spring	31762 80X00	21.7 (0.854)	7.0 (0.276)
⑳	Accumulator control valve spring	31742 80X02	22.0 (0.866)	6.5 (0.256)
㉓	Shift valve A spring	31762 80X00	21.7 (0.854)	7.0 (0.276)
⑫	Shift valve B	31762 80X00	21.7 (0.854)	7.0 (0.276)
③	Pressure modifier valve spring	31742 41X15	30.5 (1.201)	9.8 (0.386)
⑦		31742 80X16	32.0 (1.260)	6.9 (0.272)

- Replace valve springs if deformed or fatigued.

### Control valves

- Check sliding surfaces of control valves, sleeves and plugs for damage.

Retainer plates in lower body

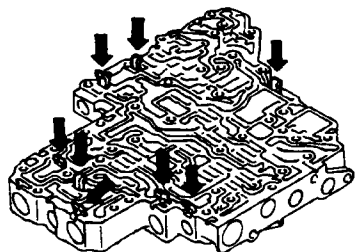

### ASSEMBLY

- Install control valves.

For installation procedures, see "ASSEMBLY" of Control Valve Upper Body. **Refer to page 51**



**Service Information RE4FO4A**

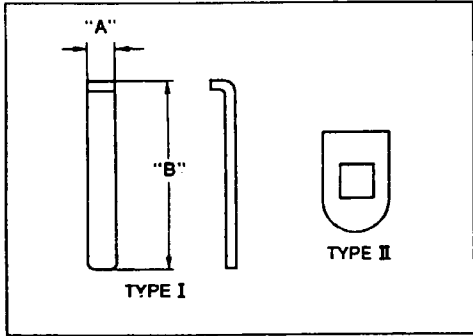

**Retainer plate**

Unit: mm (in)

Name of control valve	Length A	Length B	Type
Accumulator shift valve	6.0 (0.236)	19.5 (0.768)	
Pressure regulator valve			
Pressure clutch control			
Accumulator control valve		28.0 (1.102)	
Shift valve A			
Shuttle shift valve			
Overrun clutch control valve			
Pressure modifier valve			
Shift valve B	-	-	II

- Install proper retainer plates

## Reverse Clutch

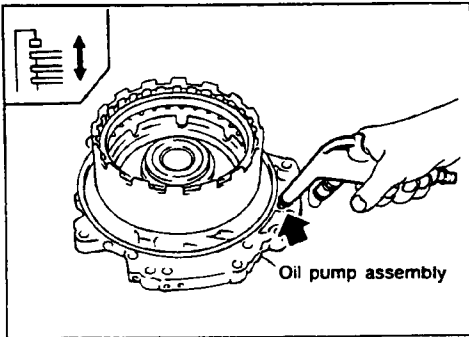
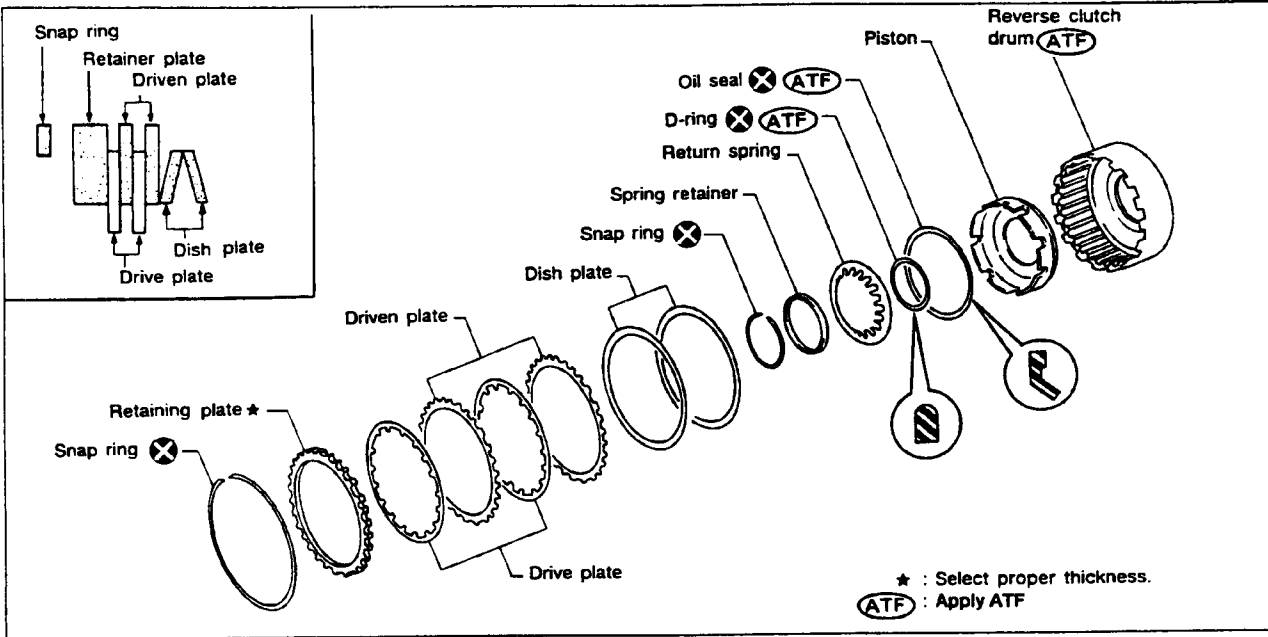

### DISASSEMBLY

1. Check operation of reverse clutch
  - a. Install seal ring onto drum support of oil pump cover and install reverse clutch assembly. Apply compressed air to oil hole.
  - b. Check to see that retaining plate moves to snap ring.
  - c. If retaining plate does not move to snap ring, D-ring or oil seal may be damaged or fluid may be leaking at piston check ball.

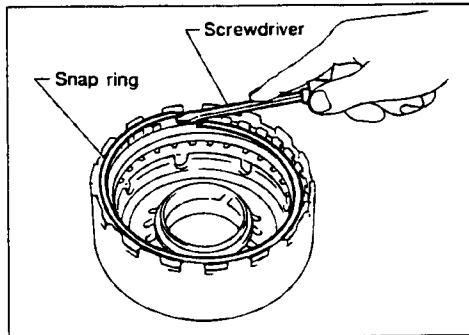

2. Remove snap ring.
3. Remove drive plates, driven plates, retaining plate, and dish plates.

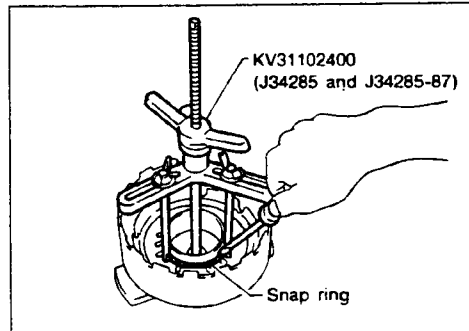

4. Set Tool on spring retainer and remove snap ring from reverse clutch drum while compressing return springs.
  - **Set Tool directly over springs.**
  - **Do not expand snap ring excessively.**
5. Remove spring retainer and return springs.



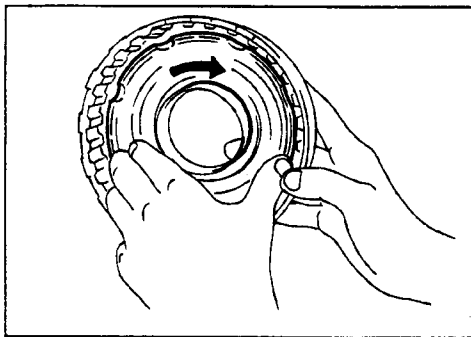

6. Remove piston from reverse clutch drum by turning it.
7. Remove D-ring and oil seal from piston.

### INSPECTION

#### Reverse clutch snap ring, spring retainer and return springs

- Check for deformation, fatigue or damage.  
If necessary, replace.

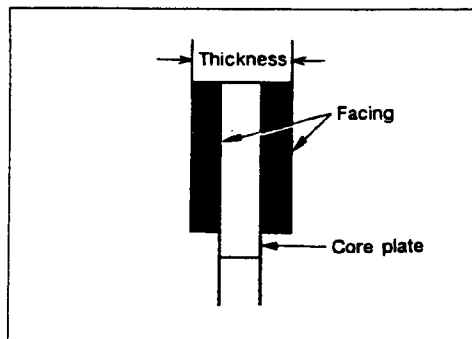

#### Reverse clutch drive plates

- Check facing for burns, cracks or damage.
- Measure thickness of facing.  
**Thickness of drive plate:**  
**Standard value: 2.0 mm (0.079 in)**  
**Wear limit: 1.8 mm (0.071 in)**
- If not within wear limit, replace.

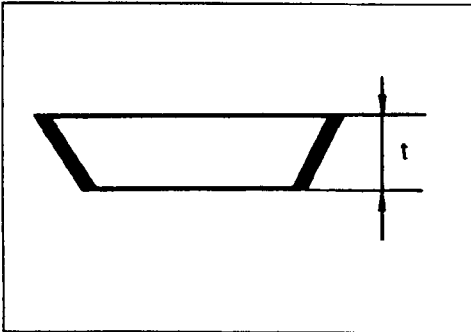

**Reverse clutch dish plates**

- Check for deformation or damage.
- Measure thickness of dish plate.  
     **Thickness of dish plate: 3.08 mm (0.1213 in)**
- If deformed or fatigued, replace.

**Reverse clutch piston**

- Make sure that check balls are not fixed.
- Apply compressed air to check ball oil hole opposite the return spring to make sure that there is no air leakage.
- Apply compressed air to oil hole on return spring side to make sure that air leaks past ball.

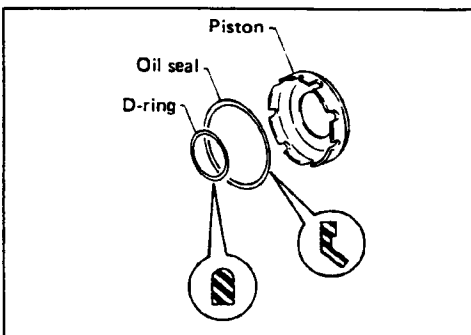

**ASSEMBLY**

1. Install D-ring and oil seal on piston.
- **Take care with the direction of oil seal.**
- **Apply ATF to both parts.**

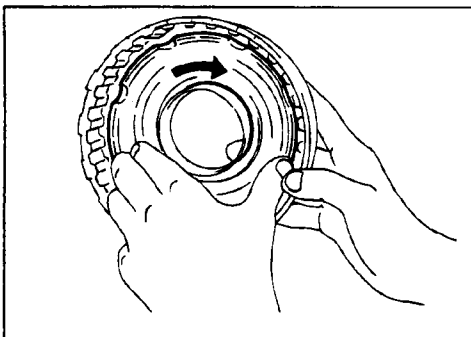

2. Install piston assembly by turning it slowly.
- **Apply ATF to inner surface of drum.**

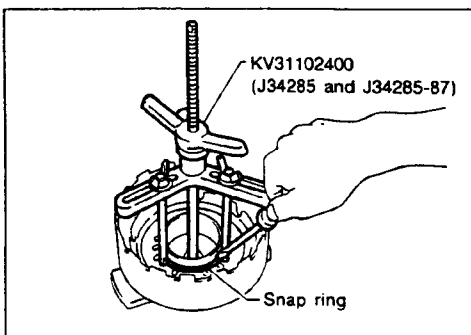

3. Install return springs and spring retainer on piston.
4. Set Tool on spring retainer and install snap ring while compressing return springs.
- **Set Tool directly over return springs.**

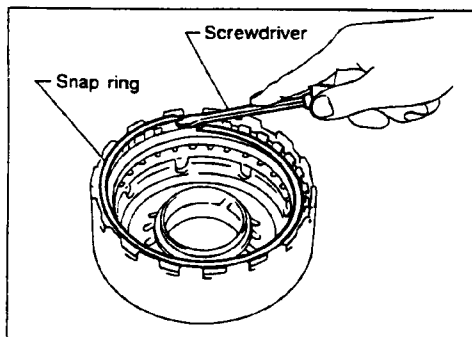

5. Install drive plates, driven plates, retaining plate and dish plates.
  - **Take care with order of plates.**
6. Install snap ring.

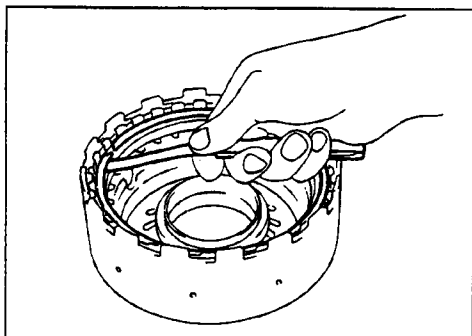

7. Measure clearance between retaining plate and snap ring. If not within allowable limit, select proper retaining plate.
 

**Specified clearance:**  
**Standard 0.5 - 0.8 mm (0.020 - 0.031 in)**  
**Allowable limit 1.2 mm (0.047 in)**  
**Retaining plate: Refer to SDS (AT-200).**

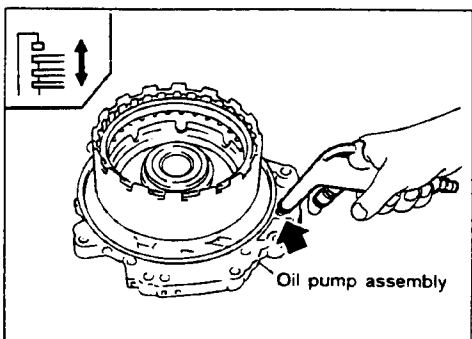

8. Check operation of reverse clutch as described in "DISASSEMBLY" of Reverse Clutch. **Refer to page 56**

### High Clutch

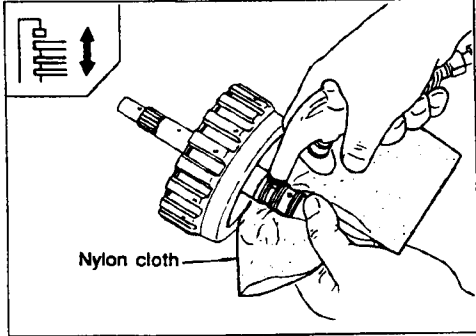
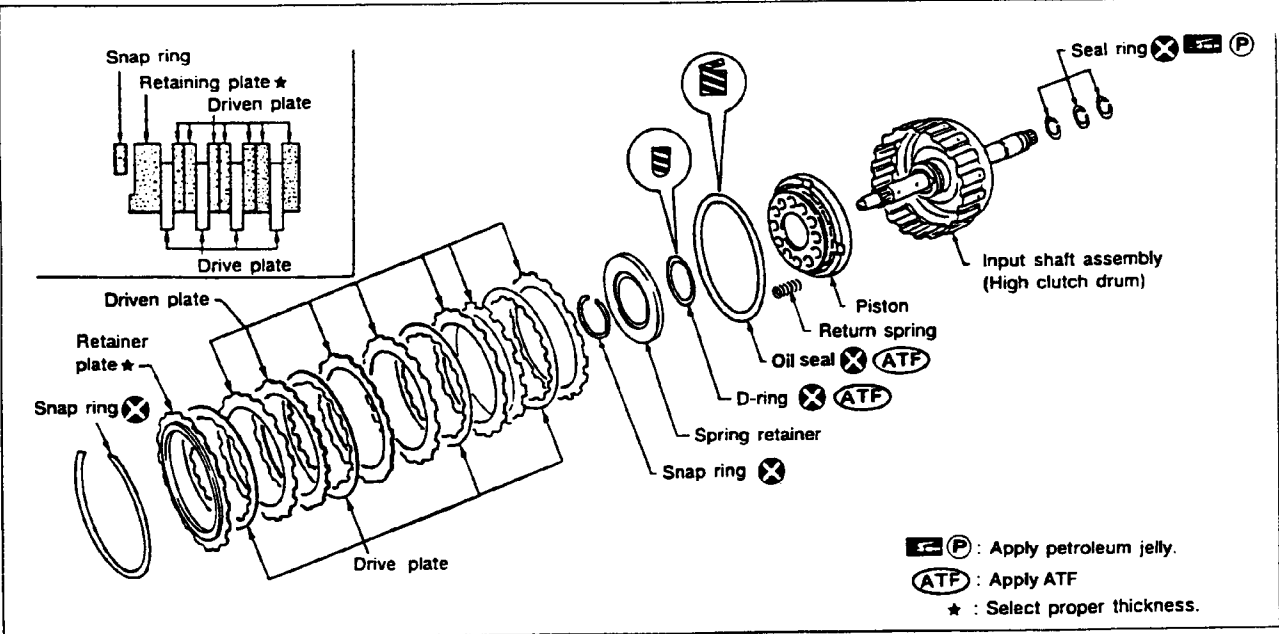

#### DISASSEMBLY

1. Check operation of high clutch.
  - a. Apply compressed air to oil hole of input shaft with nylon cloth.
    - **Stop up hole on opposite side of input shaft with nylon cloth.**
  - b. Check to see that retaining plate moves to snap ring.
  - c. If retaining plate does not move to snap ring, D-ring or oil seal may be damaged or fluid may be leaking at piston check ball.

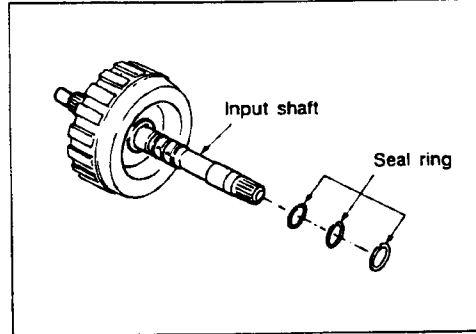

2. Remove seal rings from input shaft.
  - **Always replace when removed.**

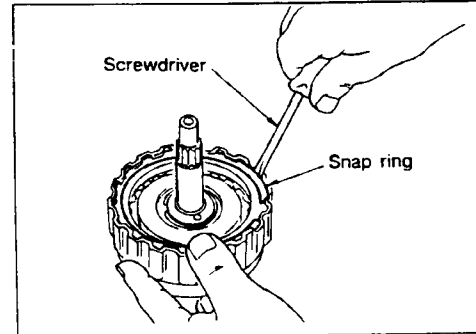

3. Remove snap ring.
4. Remove drive plates, driven plates and retaining plate.

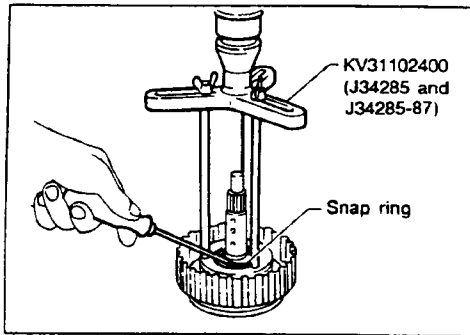

5. Set Tool on spring retainer and remove snap ring from high clutch drum while compressing return springs.
  - **Set Tool directly over springs.**
  - **Do not expand snap ring excessively.**
6. Remove spring retainer and return springs.

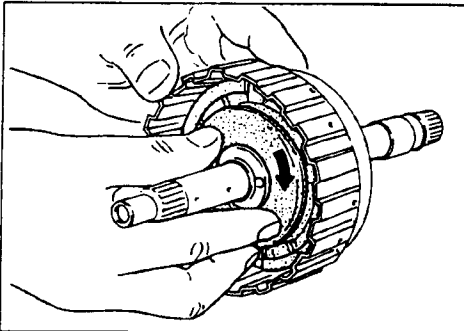

7. Remove piston from high clutch drum by turning it.

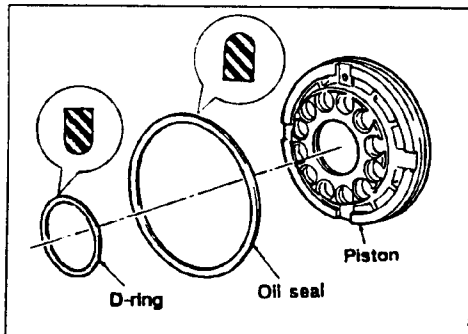

8. Remove D-rings from piston.

## INSPECTION

### High clutch snap ring, spring retainer and return springs.

- Check for deformation, fatigue or damage. If necessary, replace.
- **When replacing spring retainer and return springs, replace them as a set.**

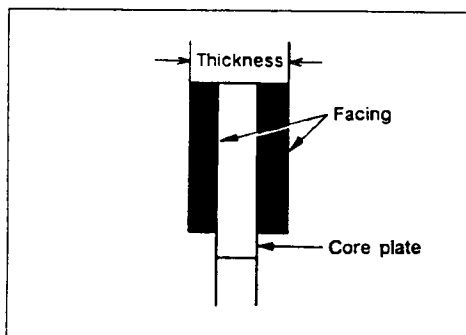

### High clutch drive plates

- Check facing for burns, cracks or damage.
- Measure thickness of facing.
  - Thickness of drive plate:**
  - Standard value 1.6 mm (0.063 in)**
  - Wear limit 1.4 mm (0.055 in)**
- If not within wear limit, replace.

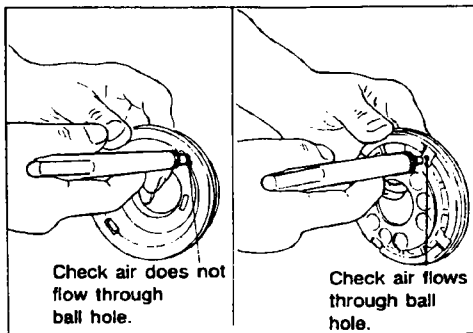

### High clutch piston

- Make sure that check balls are not fixed.
- Apply compressed air to check ball oil hole opposite the return spring to make sure that there is no air leakage.
- Apply compressed air to oil hole on return spring side to make sure that air leaks past ball.

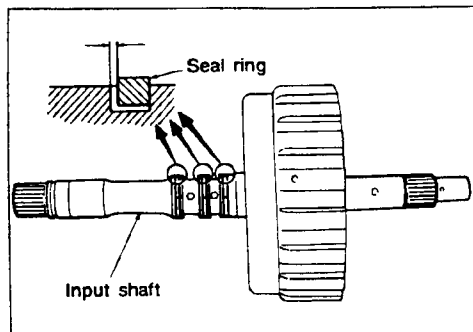

### Seal ring clearance

- Measure clearance between seal ring and ring groove.  
**Standard clearance: 0.08 - 0.23 mm (0.0031 - 0.0091 in)**  
**Allowable limit: 0.23 mm (0.0091 in)**
- If not within allowable limit, replace input shaft assembly.

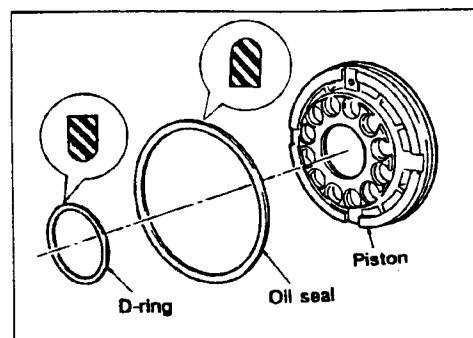

### ASSEMBLY

1. Install D-rings on piston.
  - Take care with the direction of oil seal.
  - Apply ATF to both parts.

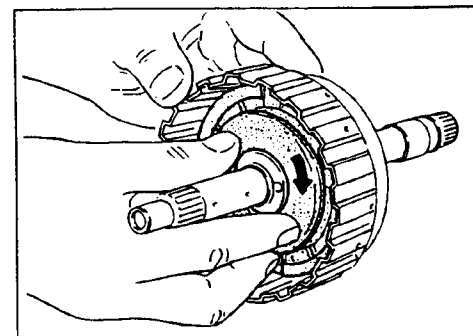

2. Install piston assembly by turning it slowly.
  - Apply ATF to inner surface of drum.

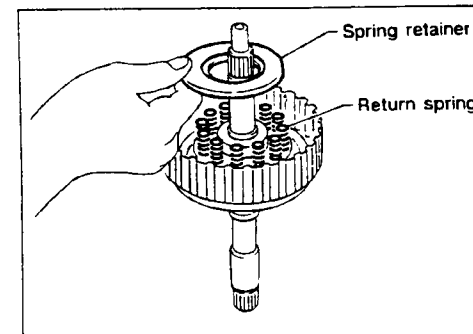

3. Install return springs and spring retainer on piston.

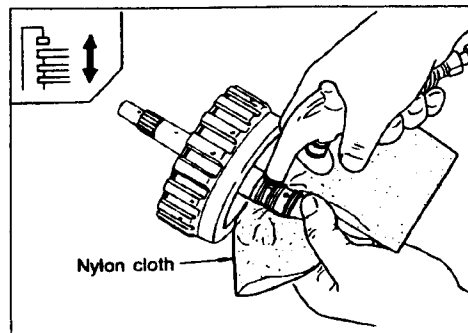
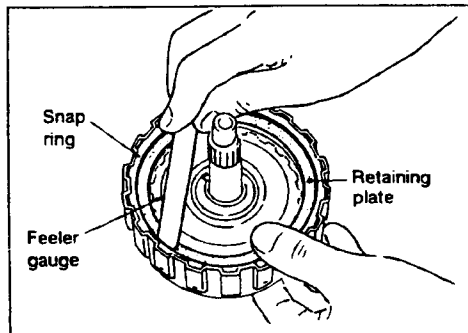
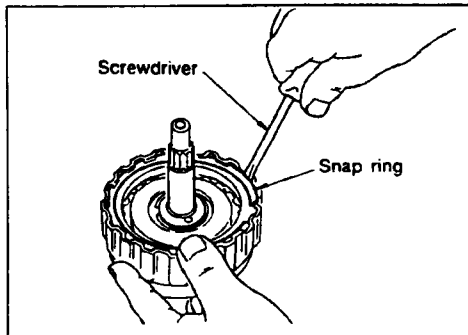
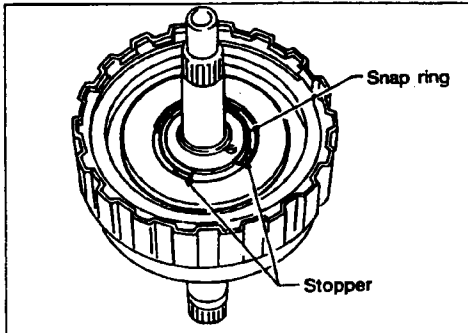
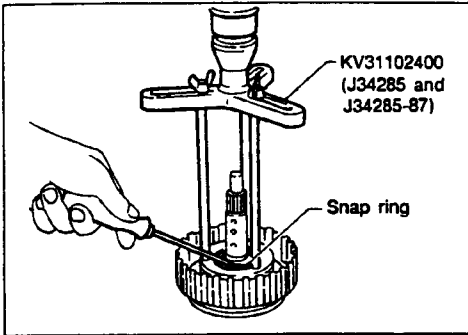

4. Set Tool on spring retainer and install snap ring while compressing return springs.
- **Set Tool directly over return springs.**

- **Do not align snap ring gap with spring retainer stopper.**

5. Install drive plates, driven plates and retaining plate.

- **Take care with direction of retaining plate and order of plates.**
6. Install snap ring.

7. Measure clearance between retaining plate and snap ring. If not within allowable limit, select proper retaining plate.

**Specified clearance:**

**Standard 1.8 - 2.2 mm (0.071 - 0.087 in)**

**Allowable limit 3.0 mm (0.118 in)**

**Retaining plate: Refer to SDS Refer to page 60**

8. Check operation of high clutch as described in "DISASSEMBLY" of High Clutch.



## Service Information RE4FO4A

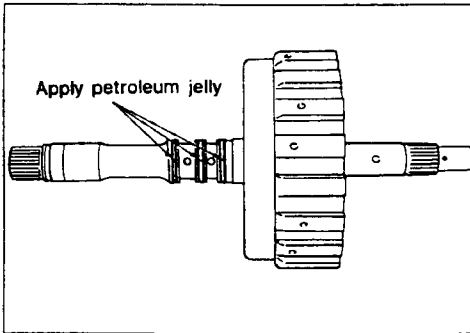

9. Install seal rings to input shaft.
- Apply petroleum jelly to seal rings.
  - Always replace when removed.

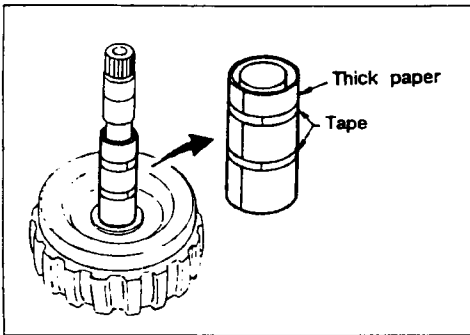

- Roll paper around seal rings to prevent seal rings from spreading.



### Forward Clutch and Overrun Clutch

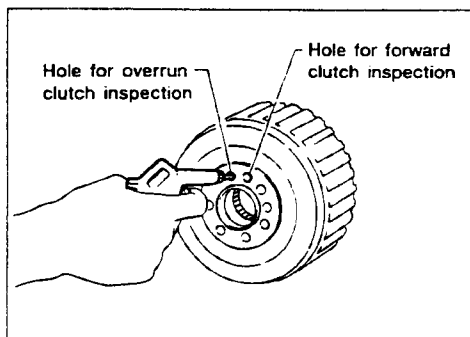
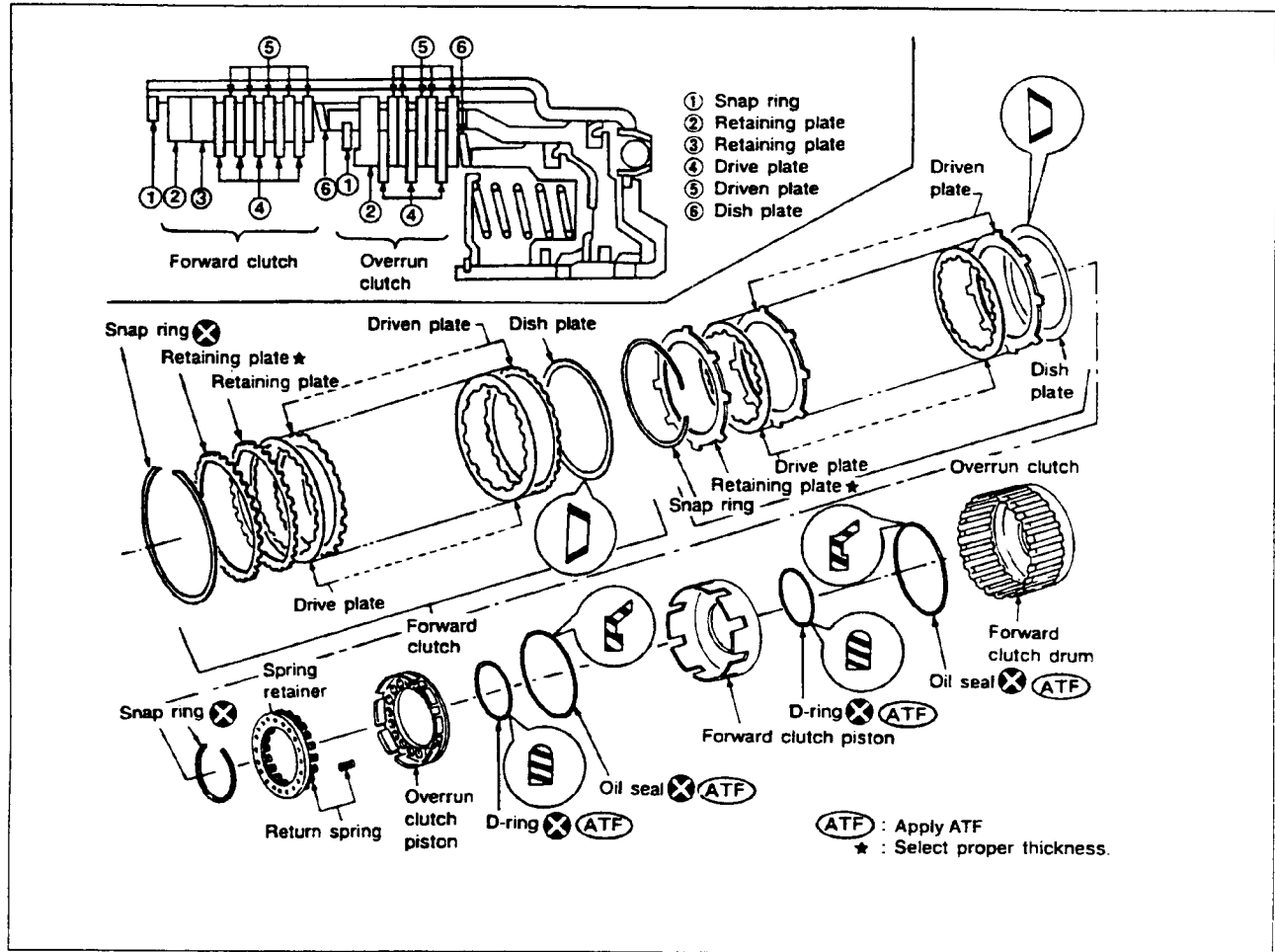

#### DISASSEMBLY

1. Check operation of forward clutch and overrun clutch.
  - a. Install bearing retainer on forward clutch drum.
  - b. Apply compressed air to oil hole of forward clutch drum.
  - c. Check to see that retaining plate moves to snap ring.
  - d. If retaining plate does not move to snap ring, D-ring or oil seal may be damaged or fluid may be leaking at piston check ball.
2. Remove snap ring for forward clutch.
3. Remove drive plates, driven plates, retaining plate and dish plate for forward clutch.

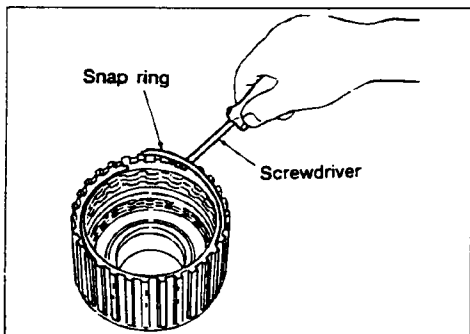

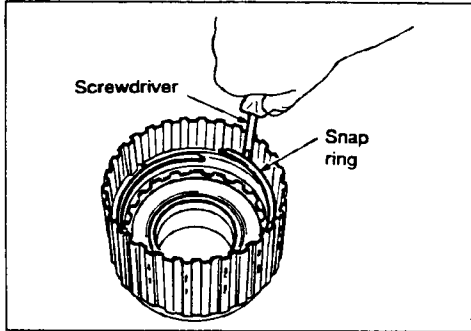

4. Remove snap ring for overrun clutch.
5. Remove drive plates, driven plates, retaining plate and dish plate for overrun clutch.

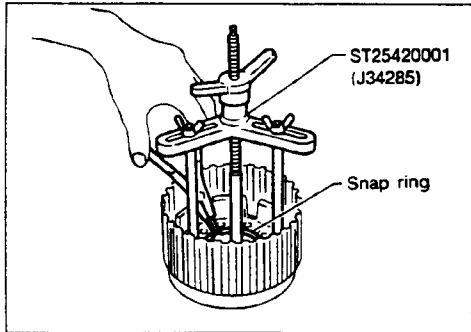

6. Set Tool on spring retainer and remove snap ring from forward clutch drum while compressing return springs.
  - **Set Tool directly over return springs.**
  - **Do not expand snap ring excessively.**
7. Remove spring retainer and return springs.
  - **Do not remove return springs from spring retainer.**

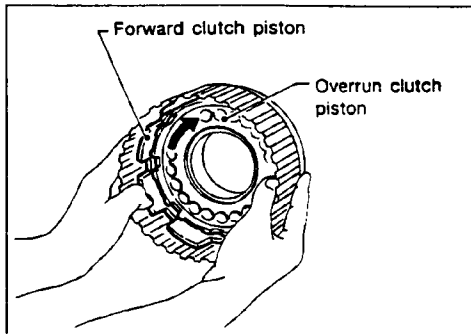

8. Remove forward clutch piston with overrun clutch piston from forward clutch drum by turning it.

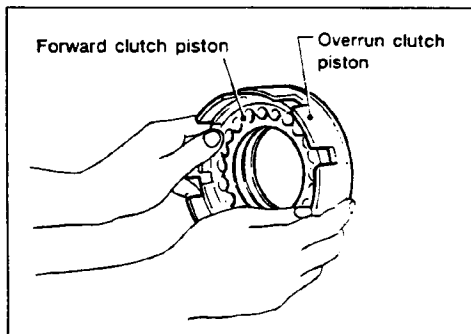

9. Remove overrun clutch piston from forward clutch piston by turning it.

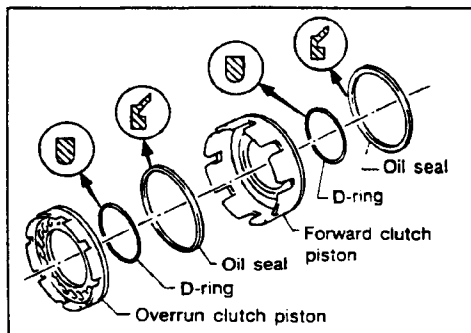

10. Remove D-rings and oil seals from forward clutch piston and overrun clutch piston.

## INSPECTION

### Snap rings, spring retainer and return springs

- Check for deformation, fatigue or damage.
- Replace if necessary.
- When replacing spring retainer and return springs, replace them as a set.

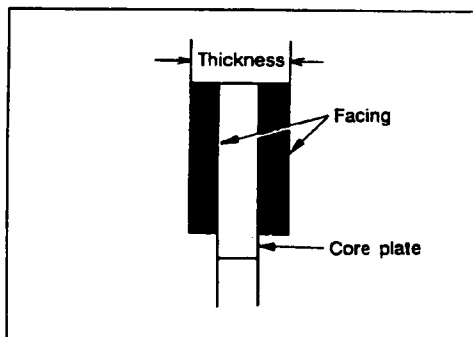

### Forward clutch and overrun clutch drive plates

- Check facing for burns, cracks or damage.
- Measure thickness of facing.

#### Thickness of drive plate:

##### Forward clutch

Standard value: 1.6 mm (0.063 in)

Wear limit: 1.4 mm (0.055 in)

##### Overrun clutch

Standard value: 1.6 mm (0.063 in)

Wear limit: 1.4 mm (0.055 in)

- If not within wear limit, replace.

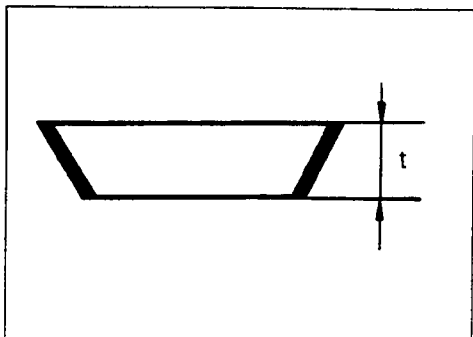

### Forward clutch and overrun clutch dish plates

- Check for deformation or damage.
- Measure thickness of dish plate.

#### Thickness of dish plate:

Forward clutch 2.7 mm (0.106 in)

Overrun clutch 2.7 mm (0.106 in)

- If deformed or fatigued, replace.

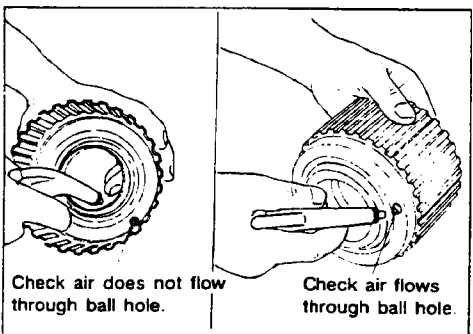

### Forward clutch drum

- Make sure that check balls are not fixed.
- Apply compressed air to check ball oil hole from outside of forward clutch drum to make sure that air leaks past ball.
- Apply compressed air to oil hole from inside of forward clutch drum to make sure that there is no air leakage.

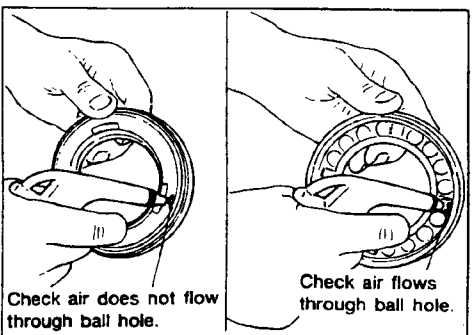

### Overrun clutch piston

- Make sure that check balls are not fixed.
- Apply compressed air to check ball oil hole opposite the return spring to make sure that there is no air leakage.
- Apply compressed air to oil hole on return spring side to make sure that air leaks past ball.

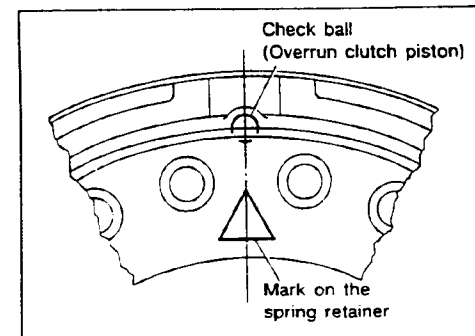
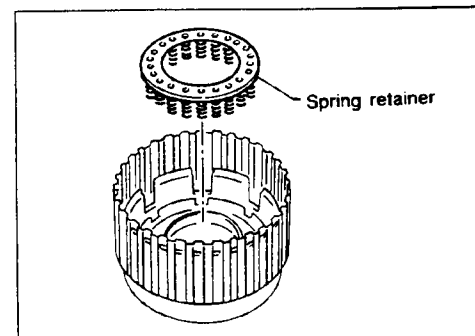
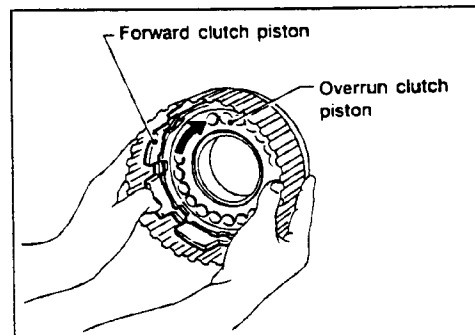
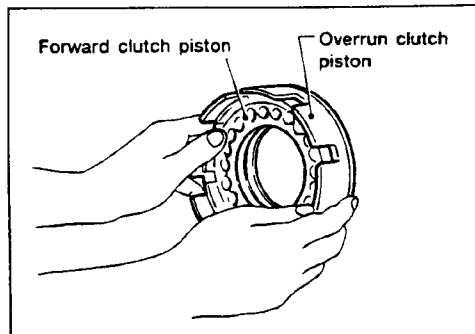
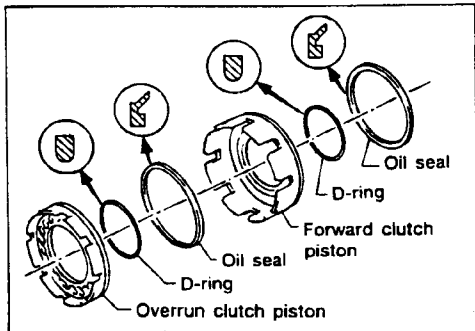

**ASSEMBLY**

1. Install D-rings and oil seals on forward clutch piston and overrun clutch piston.

- Take care with direction of oil seal.
- Apply ATF to both parts.

2. Install overrun clutch piston assembly on forward clutch piston by turning it slowly.

- Apply ATF to inner surface of forward clutch piston.

3. Install forward clutch piston assembly on forward clutch drum by turning it slowly.

- Apply ATF to inner surface of drum.

4. Install return spring on overrun clutch piston.

5. Install spring retainer on return springs.

- Align the mark on spring retainer with check ball in overrun clutch piston.

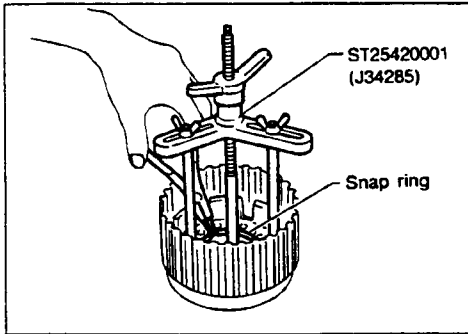

6. Set Tool on spring retainer and install snap ring while compressing return springs.
- **Set Tool directly over return springs.**

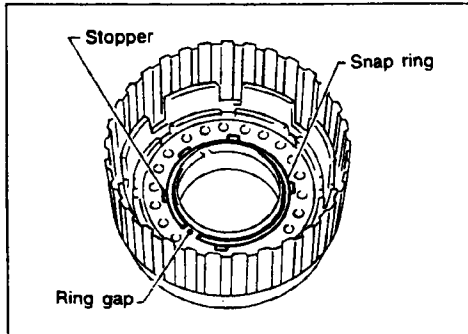

- **Do not align snap ring gap with spring retainer stopper.**

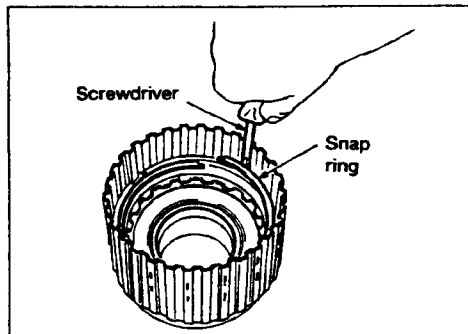

7. Install drive plates, driven plates, retaining plate and dish plate for overrun clutch.
- **Take care with order of plates.**
8. Install snap ring for overrun clutch.

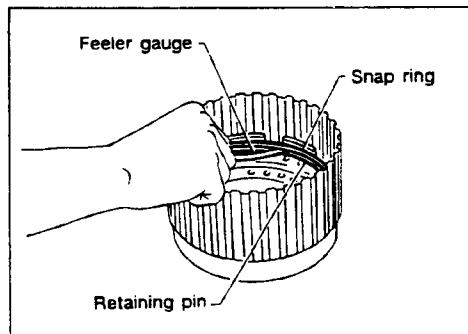

9. Measure clearance between overrun clutch retaining plate and snap ring.  
If not within allowable limit, select proper retaining plate.  
**Specified clearance:**  
Standard 0.7 - 1.1 mm (0.028 - 0.043 in)  
Allowable limit 1.7 mm (0.067 in)  
Overrun clutch retaining plate: **Refer to page 65**

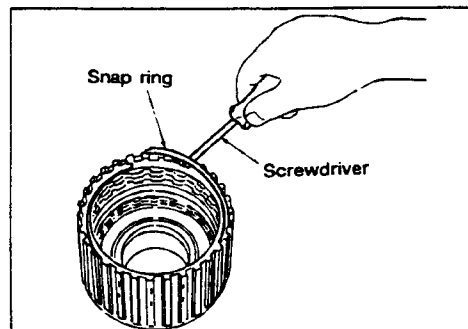

10. Install drive plates, driven plates, retaining plate and dish plate for forward clutch.
- **Take care with order of plates.**
11. Install snap ring for forward clutch.

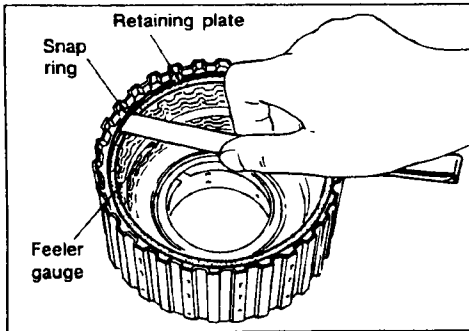

12. Measure clearance between forward clutch retaining plate and snap ring.

If not within allowable limit, select proper retaining plate.

**Specified clearance:**

**Standard 0.45 - 0.85 mm (0.0177 - 0.0335 in)**

**Allowable limit 1.85 mm (0.0728 in)**

**Forward clutch retaining plate: Refer to page 65**

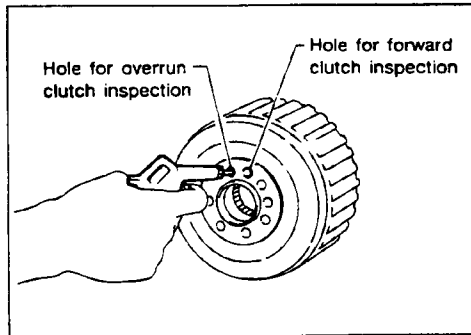

13. Check operation of forward clutch as described in "DISASSEMBLY" of Forward Clutch and Overrun Clutch. Refer to AT-150.

14. Check operation of overrun clutch as described in "DISASSEMBLY" of Forward Clutch and Overrun Clutch.

**Refer to page 100**

## Low & Reverse Brake

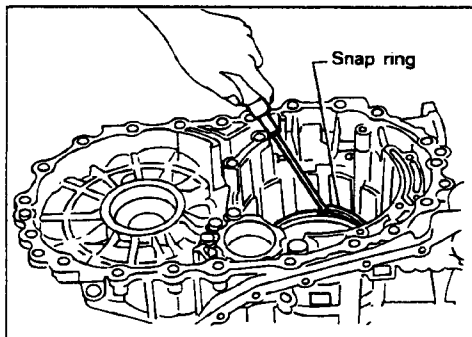
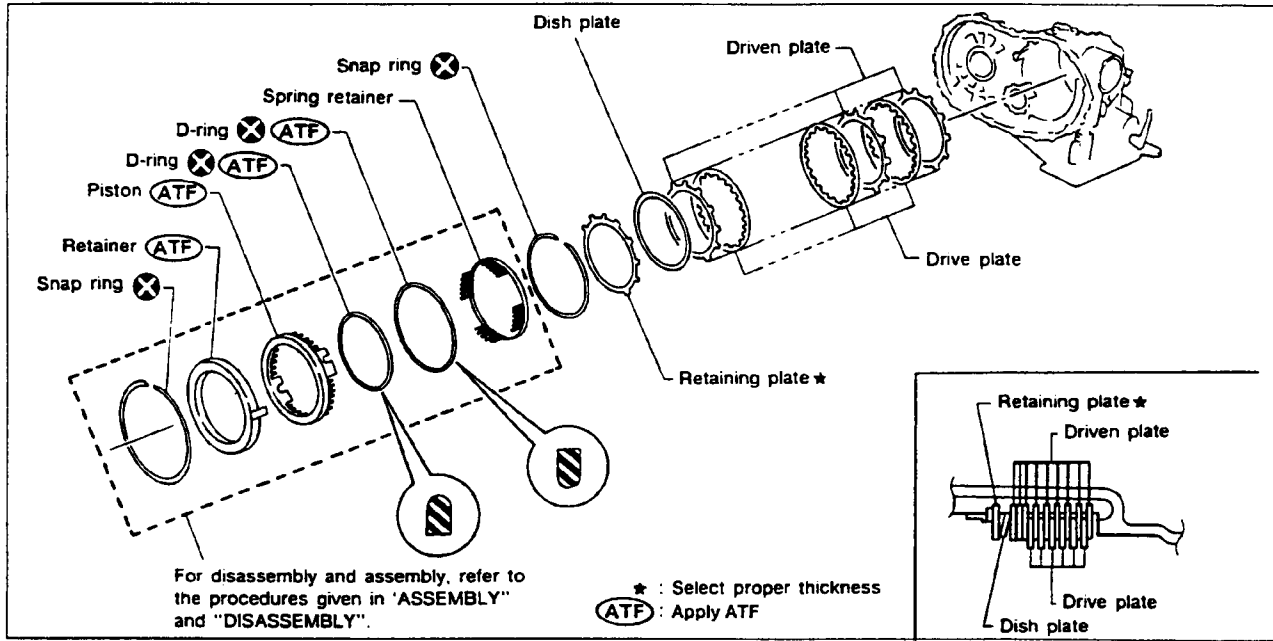

### DISASSEMBLY

1. Stand transmission case.
2. Remove snap ring.
3. Remove dish plate, retaining plate, drive plates and driven plates from transmission case.

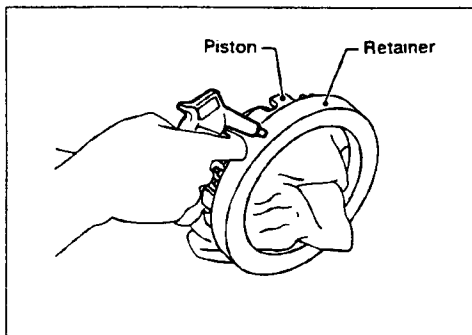

4. In order to remove piston, apply compressed air to oil hole of retainer while holding piston.
  - **Apply air gradually and allow piston to come out evenly.**

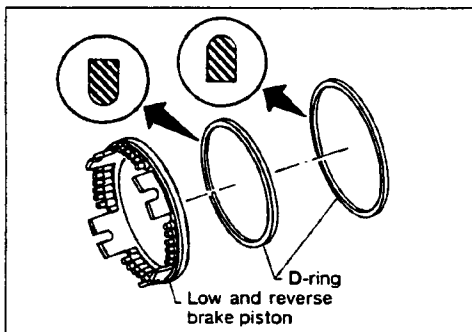

5. Remove D-rings from piston.

### INSPECTION

#### Low & reverse clutch snap ring, spring retainer and return springs

- Check for deformation, fatigue or damage. If necessary, replace.
- **When replacing spring retainer and return springs, replace them as a set.**

#### Low & reverse brake drive plate

- Check facing for burns, cracks or damage.
- Measure thickness of facing.  
**Thickness of drive plate:**  
**Standard value 1.8 mm (0.071 in)**  
**Wear limit 1.6 mm (0.063 in)**
- If not within wear limit, replace.

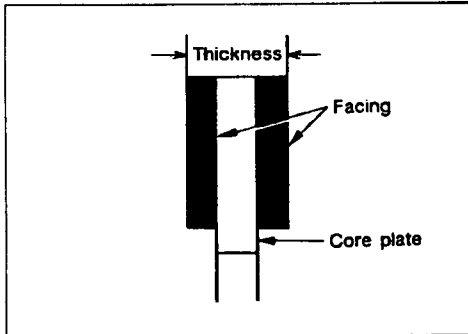

### ASSEMBLY

1. Install D-rings on piston.
  - Take care with the direction of oil seal.
  - Apply ATF to both parts.
2. Set and align piston with retainer.
  - This operation is required in order to engage the protrusions of piston to return springs correctly. Further procedures are given in "ASSEMBLY".
3. Install driven plates, drive plates, retaining plate and dish plate on transmission case.
  - Take care with order of plates and direction of dish plate.

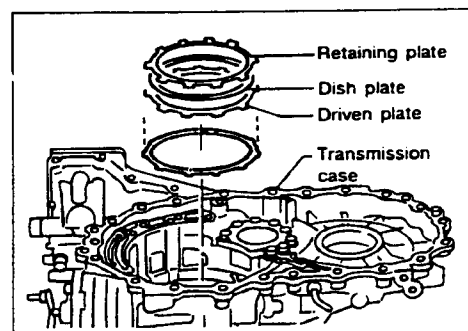
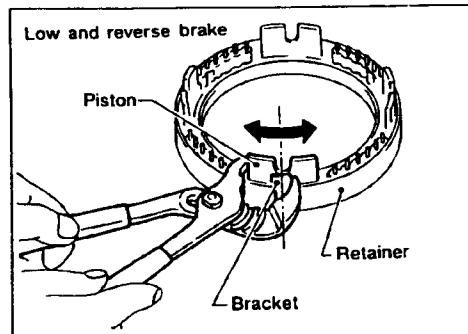
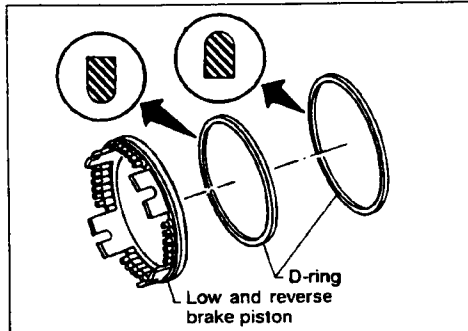



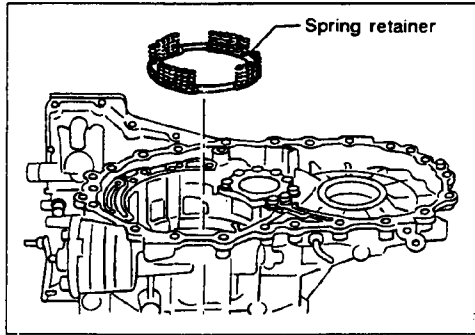

4. Install snap ring.

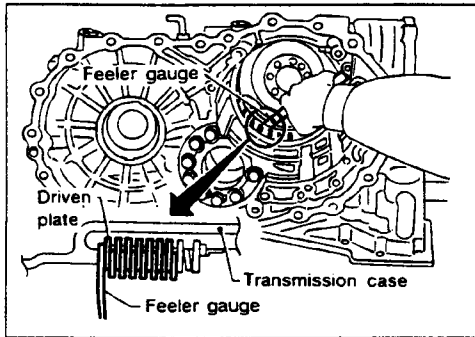

5. Measure clearance between driven plate and transmission case. If not within allowable limit, select proper retaining plate. (front side)

**Specified clearance:**

**Standard 1.7 - 2.1 mm (0.067 - 0.083 in)**

**Allowable limit 3.3 mm (0.130 in)**

**Retaining plate: Refer to SDS**

### Rear Internal Gear, Forward Clutch Hub and Overrun Clutch Hub

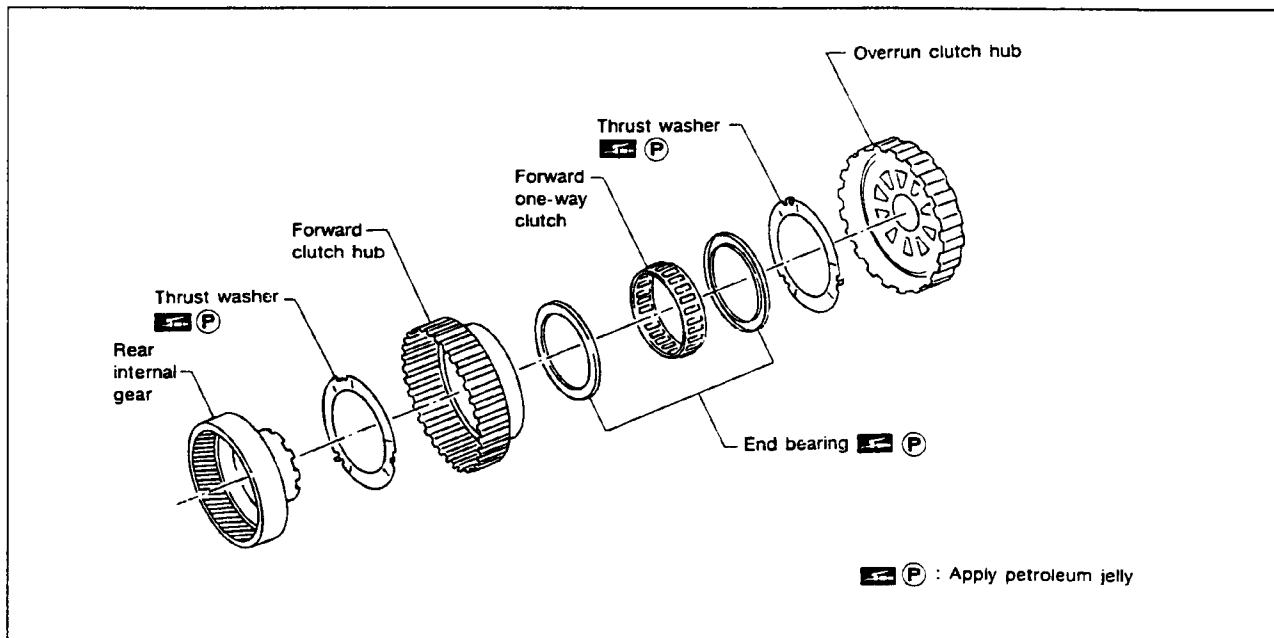

### Overrun Clutch Hub

#### DISASSEMBLY

1. Remove overrun clutch hub and thrust washer from forward clutch hub.

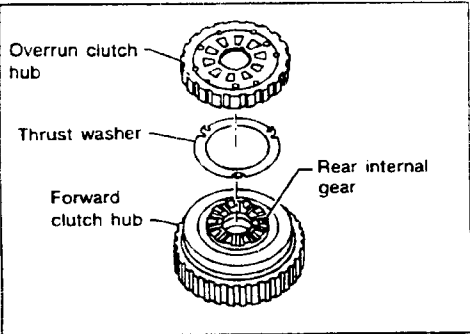

2. Remove forward clutch hub from rear internal gear.

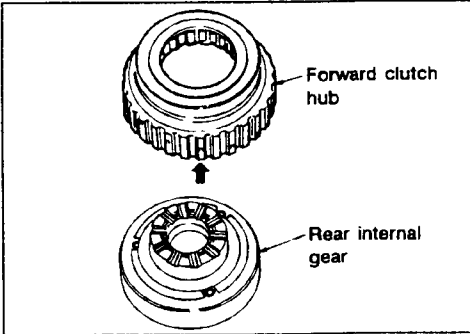

3. Remove end bearing from rear internal gear.

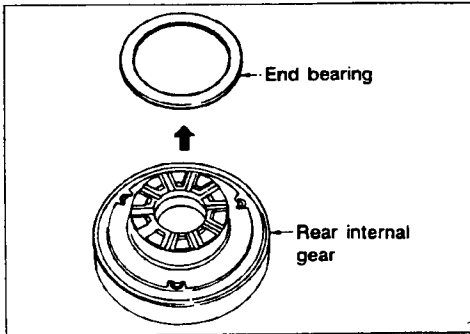

4. Remove thrust washer from rear internal gear.

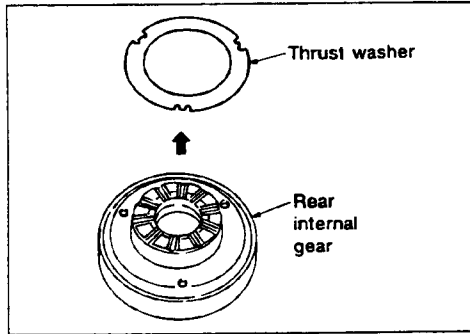

5. Remove end bearing from forward one-way clutch.

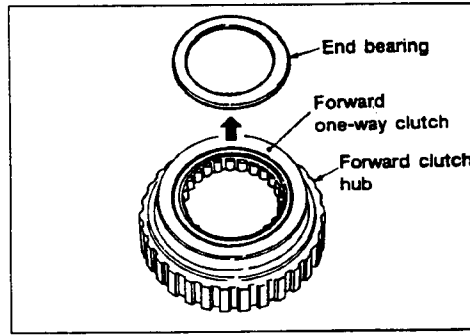

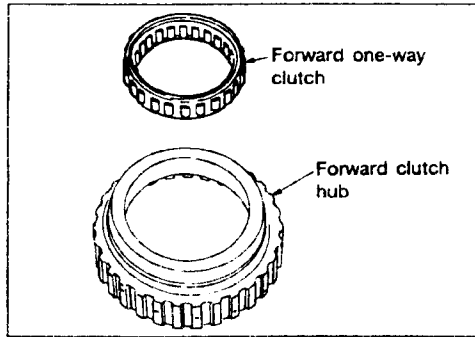

### Overrun Clutch Hub

- Remove forward one-way clutch from forward clutch hub.

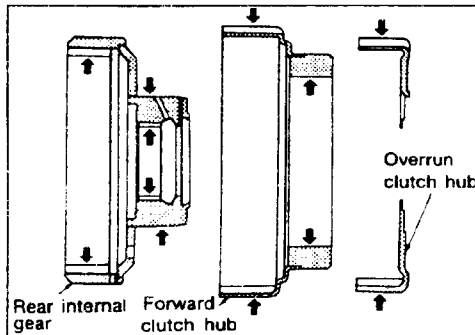

### INSPECTION

#### Rear internal gear, forward clutch hub and overrun clutch hub

- Check rubbing surfaces for wear or damage.

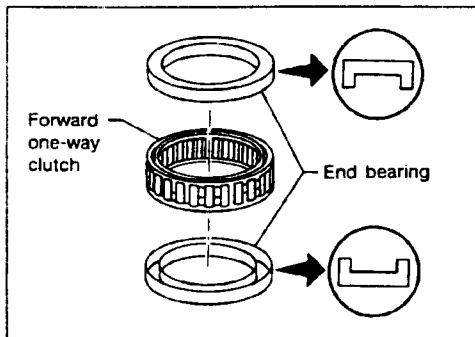

#### End bearings and forward one-way clutch

- Check end bearings for deformation and damage.
- Check forward one-way clutch for wear and damage.

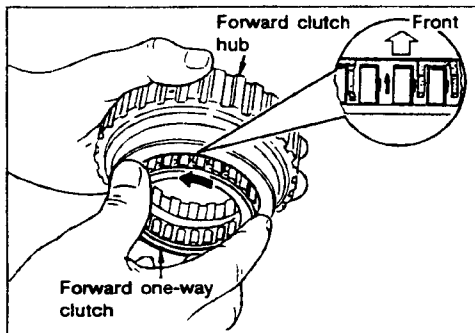

### ASSEMBLY

- Install forward one-way clutch on forward clutch.
- Take care with the direction of forward one-way clutch.

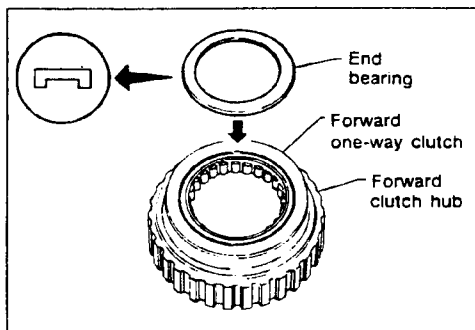

- Install end bearing on forward one-way clutch.
- Apply petroleum jelly to end bearing.

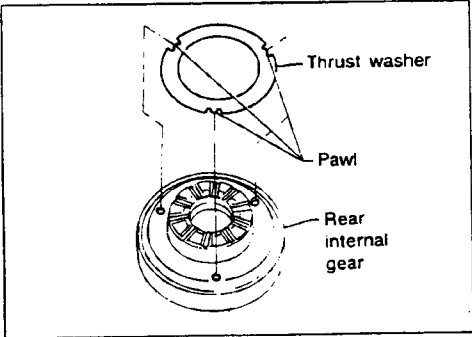

**Overrun Clutch Hub :**

3. Install thrust washer on rear internal gear.
  - Apply petroleum jelly to thrust washer.
  - Align hooks of thrust washer with holes of rear internal gear.

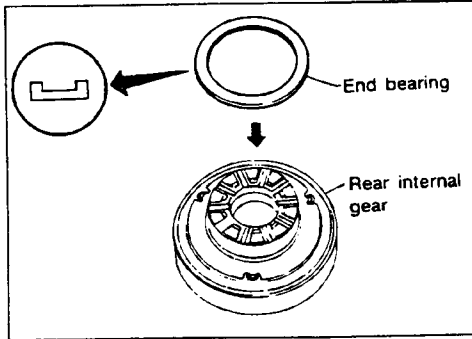

4. Install end bearing on rear internal gear.
  - Apply petroleum jelly to end bearing.

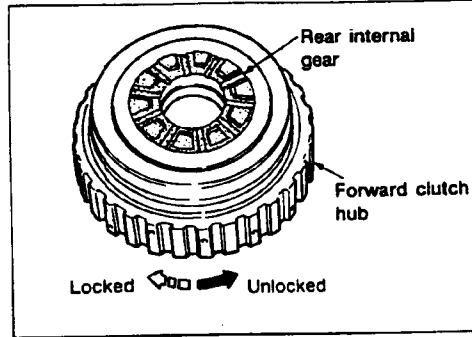

5. Install forward clutch hub on rear internal gear.
  - Check operation of forward one-way clutch.

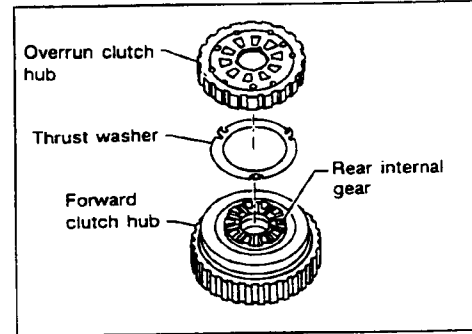

6. Install thrust washer and overrun clutch hub.
  - Apply petroleum jelly to thrust washer.
  - Align hooks of thrust washer with holes of overrun clutch hub.
  - Align projections of rear internal gear with holes of overrun clutch hub.

### Output Shaft, Idler Gear, Reduction Gear and Bearing Retainer

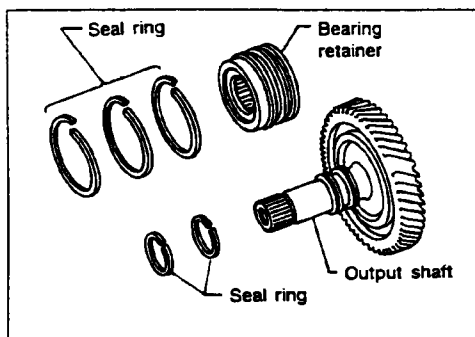
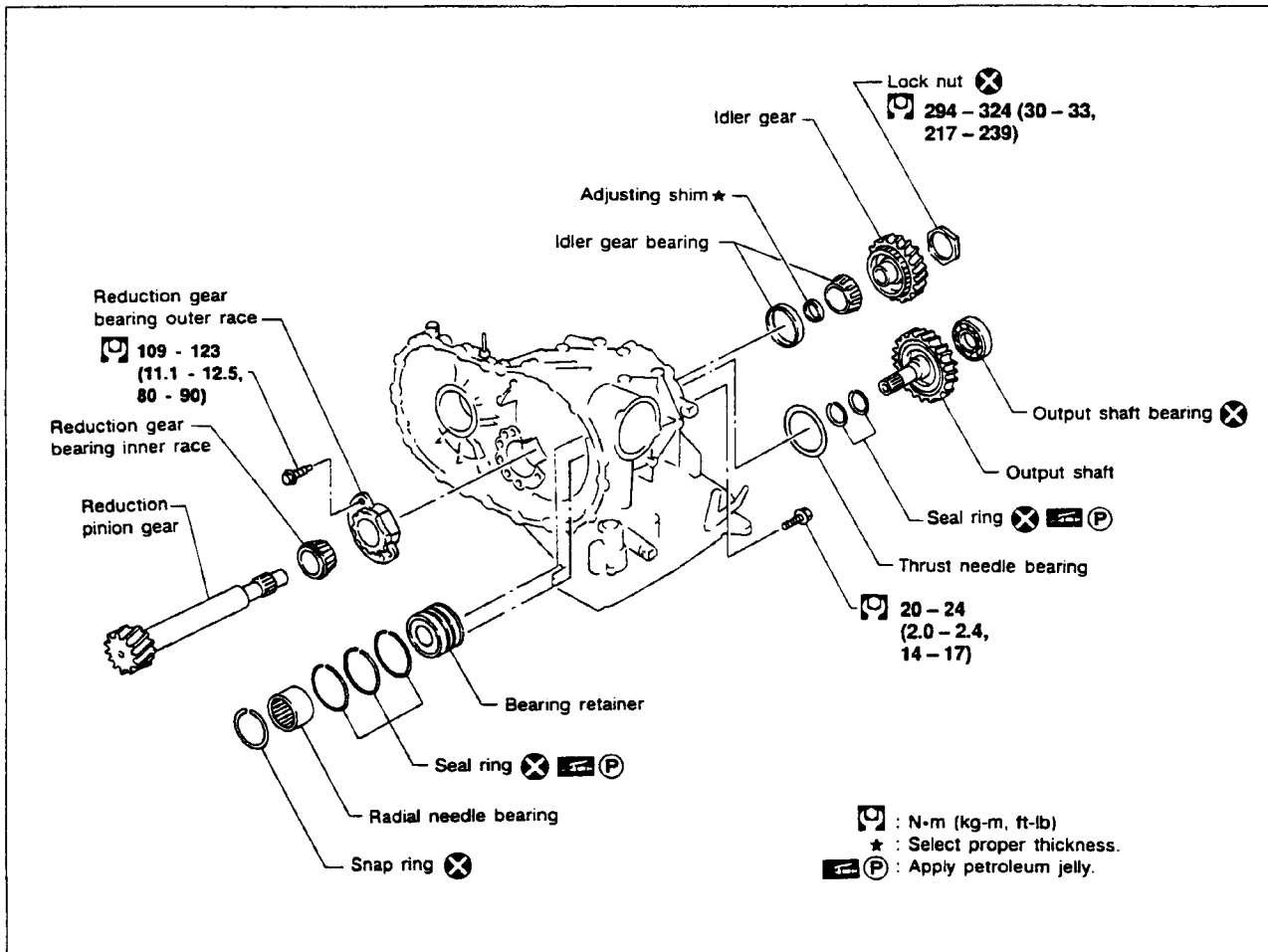

#### DISASSEMBLY

1. Remove seal rings from output shaft and bearing retainer.

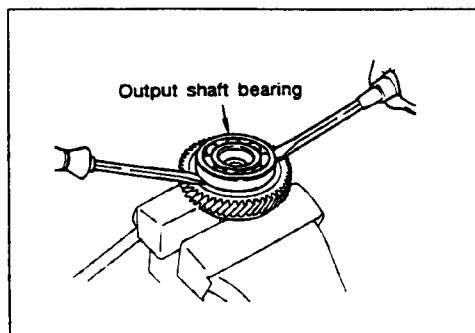

2. Remove output shaft bearing with screwdrivers.

- Always replace bearing with a new one when removed.
- Do not damage output shaft.

### Bearing Retainer

3. Remove snap ring from bearing retainer.

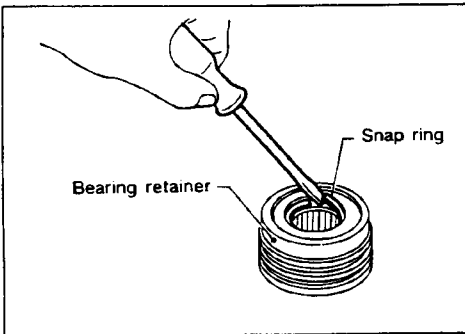

4. Remove needle bearing from bearing retainer.

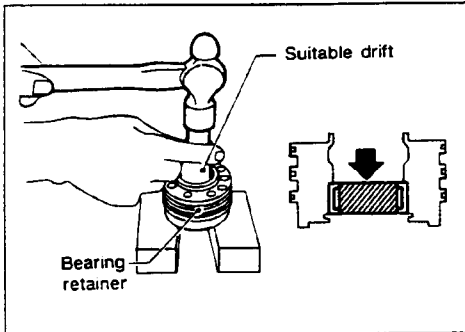

5. Remove idler gear bearing inner race from idler gear.

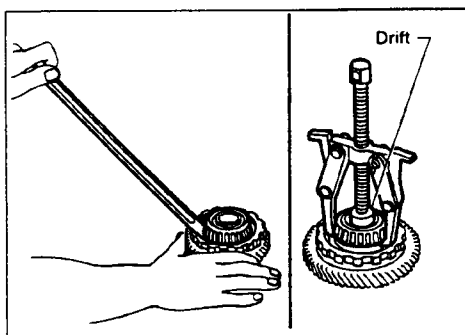

6. Remove idler gear bearing outer race from transmission case.

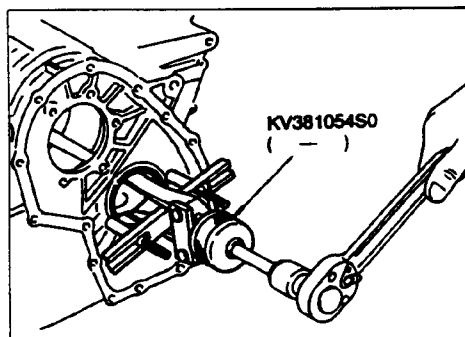

7. Press out reduction gear bearing inner race from reduction gear.

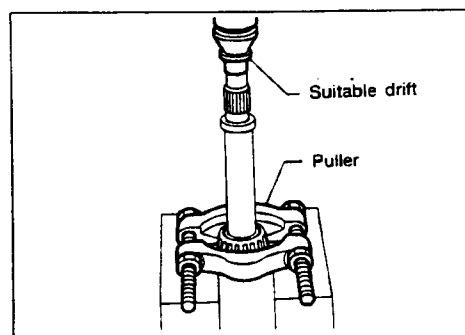

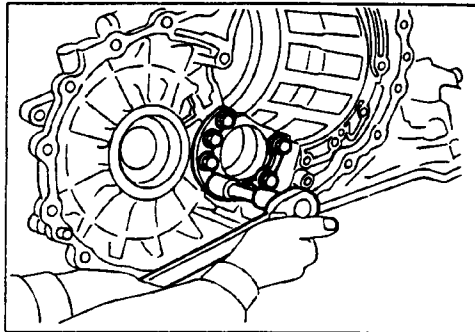

### Bearing Retainer

8. Remove reduction gear bearing outer race from transmission case.

### INSPECTION

#### Output shaft, idler gear and reduction gear

- Check shafts for cracks, wear or bending.
- Check gears for wear, chips and cracks.

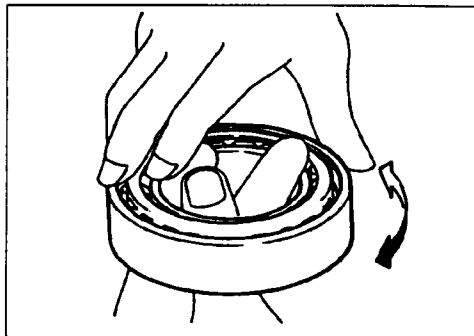

#### Bearing

- Make sure bearings roll freely and are free from noise, cracks, pitting or wear.
- **When replacing taper roller bearing, replace outer and inner race as a set.**

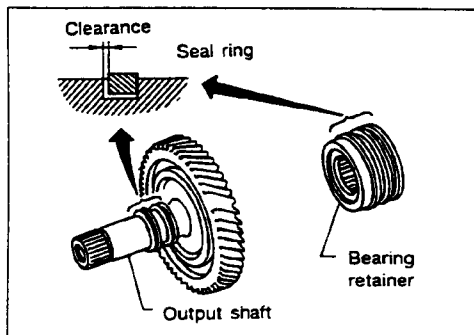

#### Seal ring clearance

- Install new seal rings to output shaft.
- Measure clearance between seal ring and ring groove of output shaft.
  - Standard clearance:**  
0.10 - 0.25 mm (0.0039 - 0.0098 in)
  - Allowable limit:**  
0.25 mm (0.0098 in)
- If not within allowable limit, replace output shaft.
- Install new seal rings to bearing retainer.
- Measure clearance between seal ring and ring groove of bearing retainer.
  - Standard clearance:**  
0.10 - 0.30 mm (0.0039 - 0.0118 in)
  - Allowable limit:**  
0.30 mm (0.0118 in)
- If not within allowable limit, replace bearing retainer.

### Bearing Retainer

#### ASSEMBLY

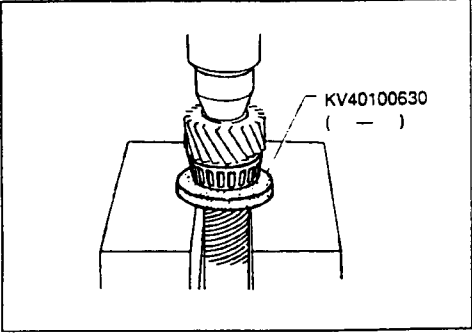

1. Press reduction gear bearing inner race on reduction gear

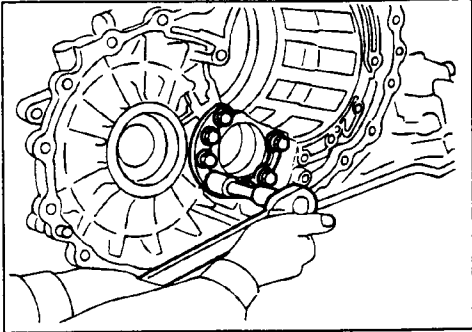

2. Install reduction gear bearing outer race on transmissio case.

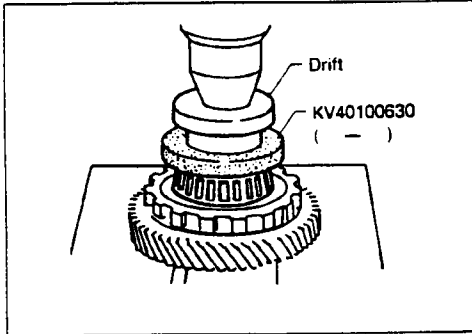

3. Press idler gear bearing inner race on idler gear.

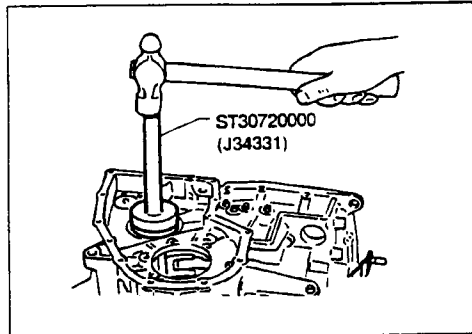

4. Install idler gear bearing outer race on transmission case.

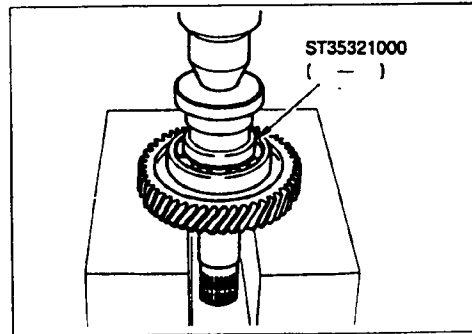

5. Press output shaft bearing on output shaft.



### Bearing Retainer

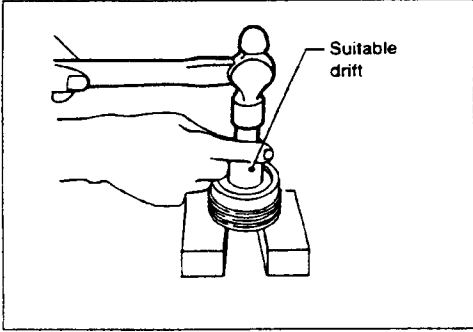

6. Press needle bearing on bearing retainer.

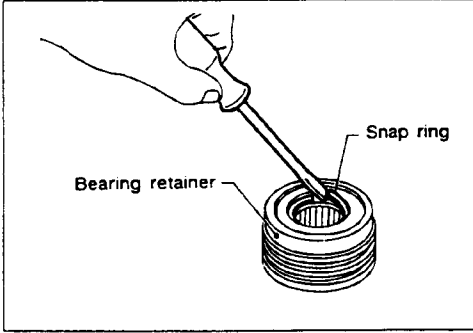

7. Install snap ring on to bearing retainer.

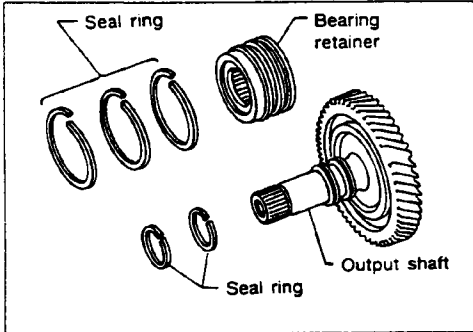

8. Install new seal rings to output shaft and bearing retainer carefully after packing ring grooves with petroleum jelly.

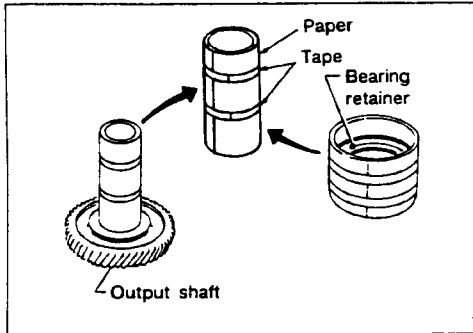

- Roll paper around seal rings to prevent seal rings from spreading.

**Band Servo Piston Assembly**

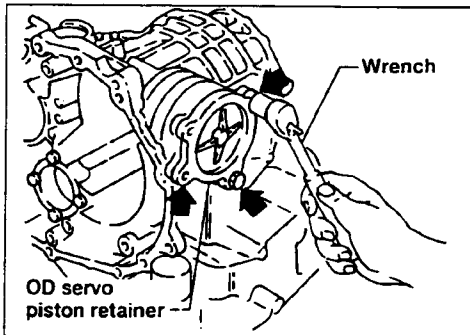
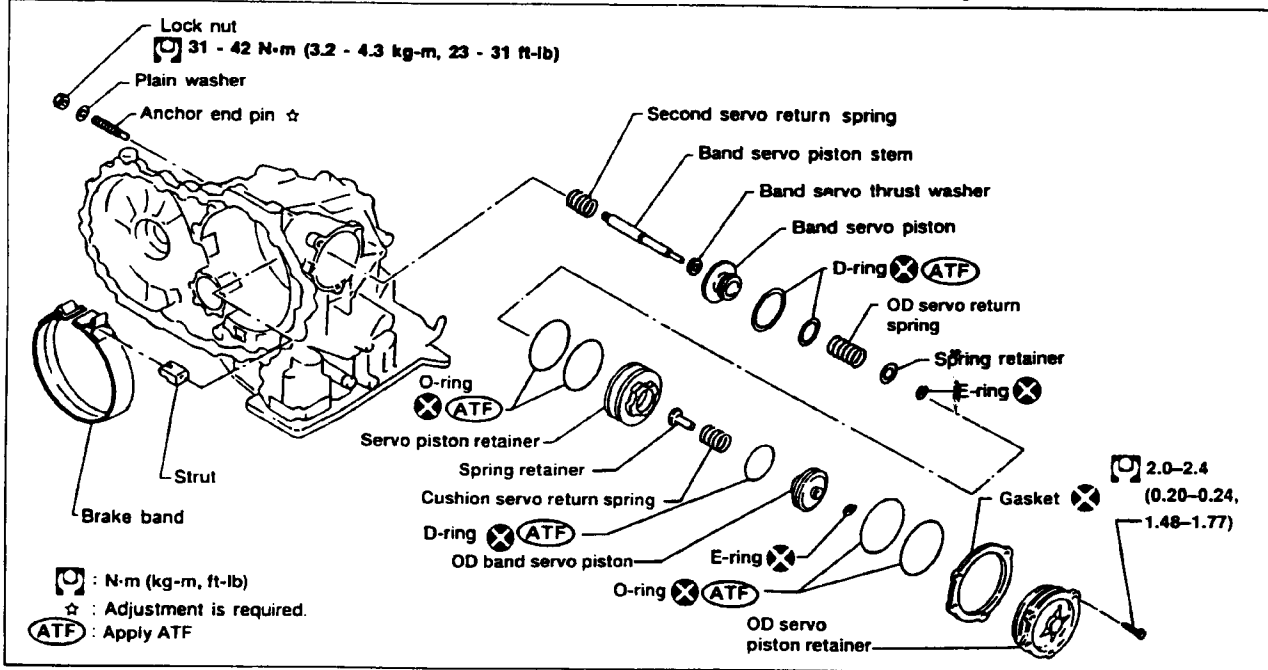

**DISASSEMBLY**

1. Remove band servo piston fixing bolts.

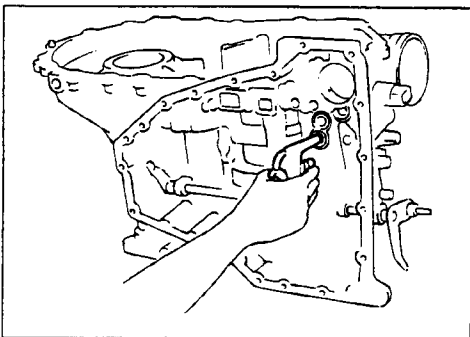

2. Apply compressed air to oil hole in transmission case to remove OD servo piston retainer and band servo piston assembly.

- **Hold band servo piston assembly with a rag.**

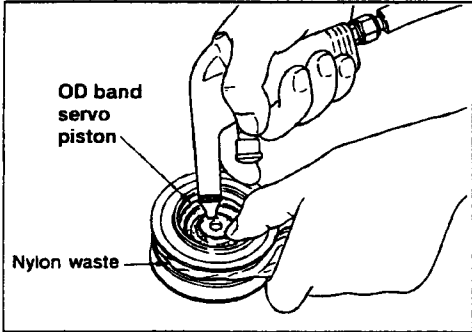

3. Apply compressed air to oil hole in OD servo piston retainer to remove OD band servo piston from retainer.
  - Hold OD band servo piston while applying compressed air.

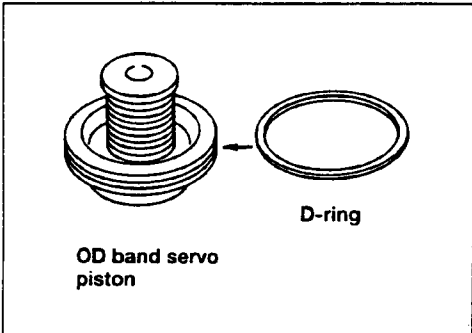

4. Remove D-ring from OD band servo piston.

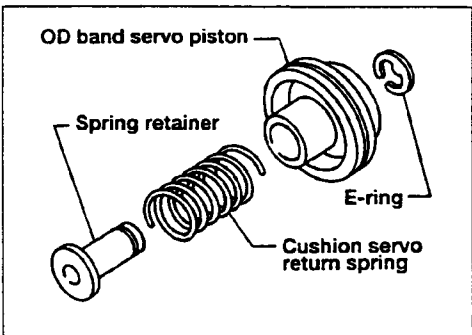

5. Remove E-ring, cushion servo return spring and spring retainer from OD band servo piston.

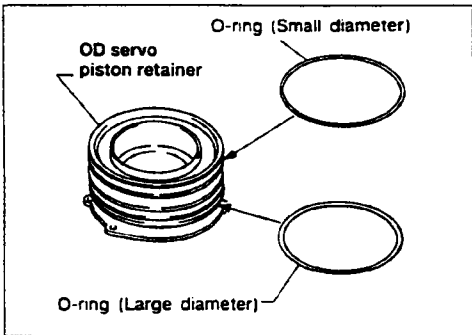

6. Remove O-rings from OD servo piston retainer.

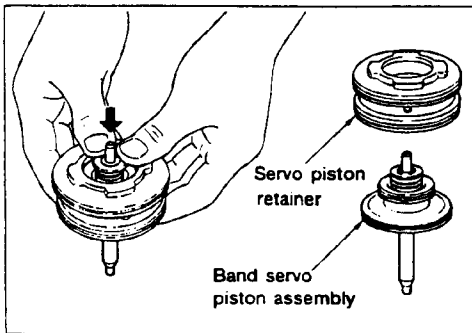

7. Remove band servo piston assembly from servo piston retainer by pushing it forward.

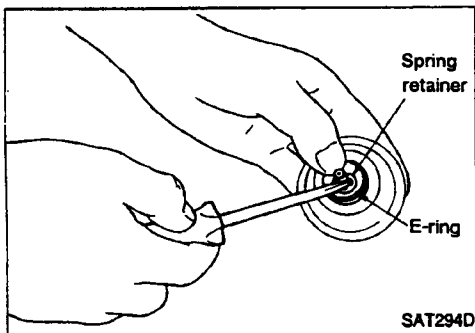

8. Place piston stem end on a wooden block. While pushing servo piston spring retainer down, remove E-ring.

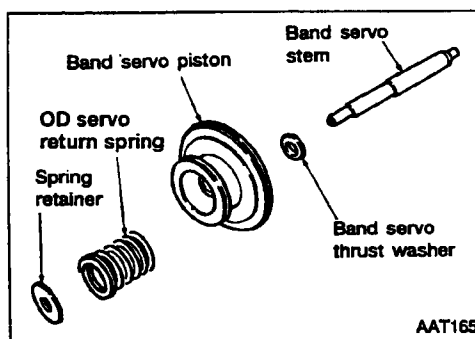

9. Remove OD servo return spring, band servo thrust washer and band servo piston stem from band servo piston.

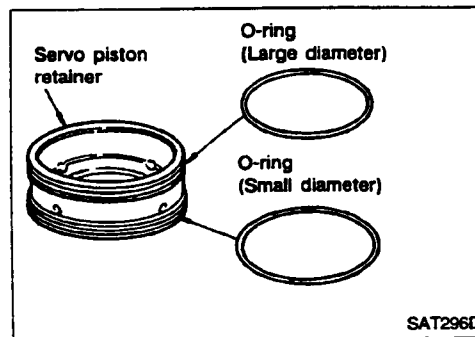

10. Remove O-rings from servo piston retainer.

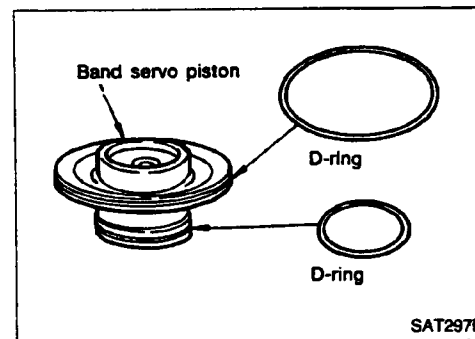

11. Remove D-rings from band servo piston.

### INSPECTION

#### Pistons, retainers and piston stem

- Check frictional surfaces for abnormal wear or damage.

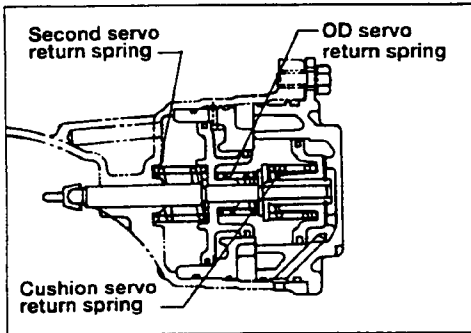

**Return springs**

- Check for deformation or damage.
- Measure free length and outer diameter.

**Inspection standard**

	Unit: mm (in)	
Parts	Free length	Outer diameter
2nd servo return spring	32.5 (1.280)	25.9 (1.020)
OD servo return spring	23.5 (0.925)	20.1 (0.791)
Cushion servo return spring	23.4 (0.921)	25.5 (1.004)

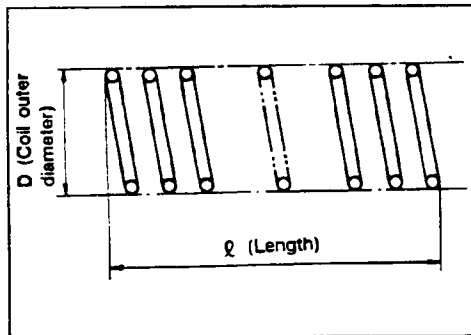

**ASSEMBLY**

1. Install D-rings to servo piston retainer.
  - Apply ATF to D-rings.
  - Pay attention to position of each O-ring.

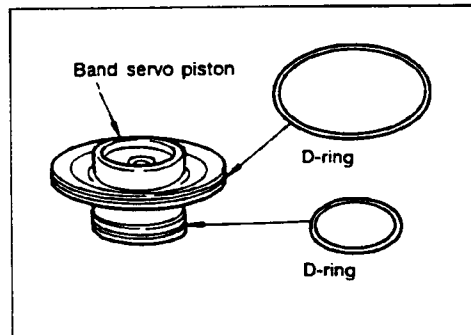

2. Install band servo piston stem, band servo thrust washer, OD servo return spring and spring retainer to band servo piston.

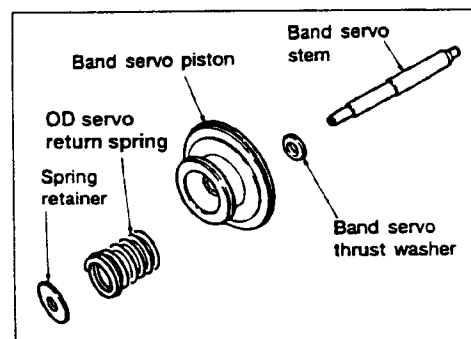

3. Place piston stem end on a wooden block. While pushing servo piston spring retainer down, install E-ring.

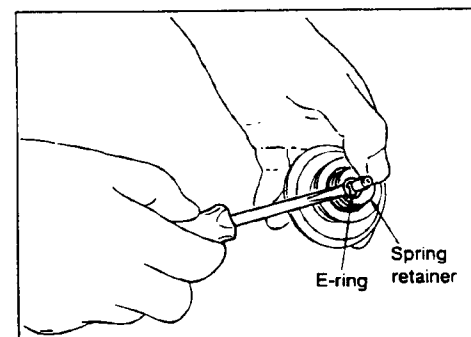

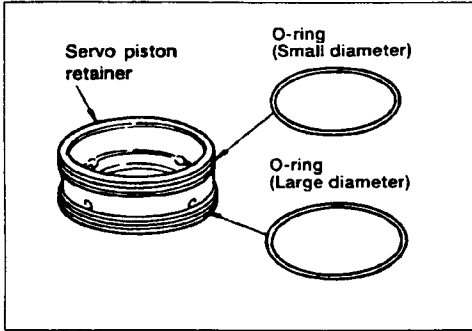

4. Install O-rings onto servo piston retainer.
  - Apply ATF to O-rings.
  - Pay attention to position of each O-ring.

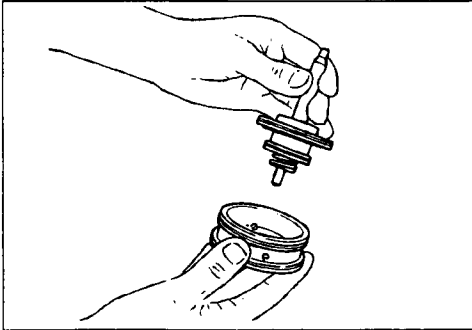

5. Install band servo piston assembly to servo piston retainer by pushing it inward.

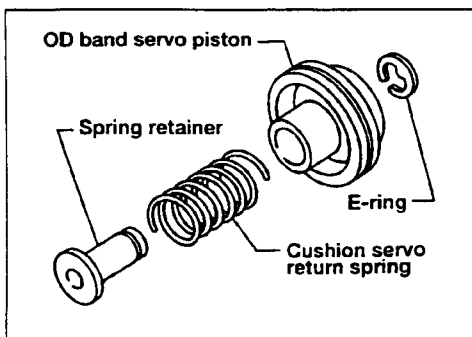

6. Install cushion servo return spring, spring retainer and E-ring into OD band servo piston.

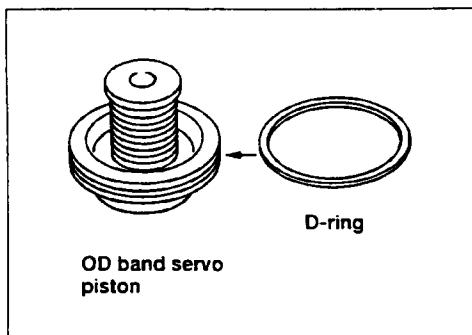

7. Install D-ring to OD band servo piston.
  - Apply ATF to D-ring.

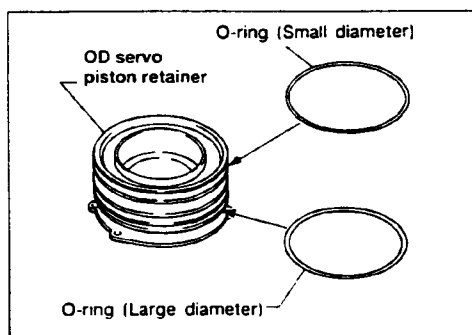

8. Install O-rings to OD servo piston retainer.
  - Apply ATF to O-rings.
  - Pay attention to position of each O-ring.

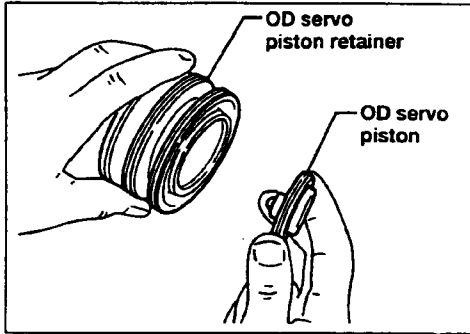

9. Install OD band servo piston to OD servo piston retainer.

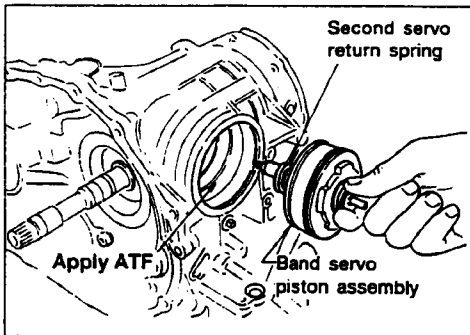

10. Install band servo piston assembly and 2nd servo return spring to transmission case.

- Apply ATF to O-ring of band servo piston and transmission case.

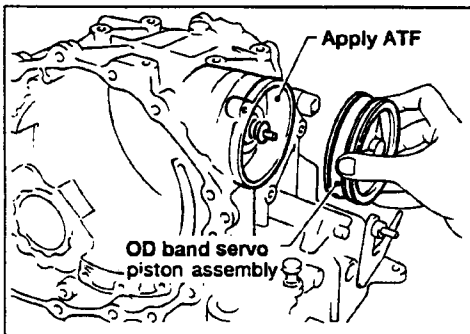

11. Install OD band servo piston assembly to transmission case.

- Apply ATF to O-ring of band servo piston and transmission case.

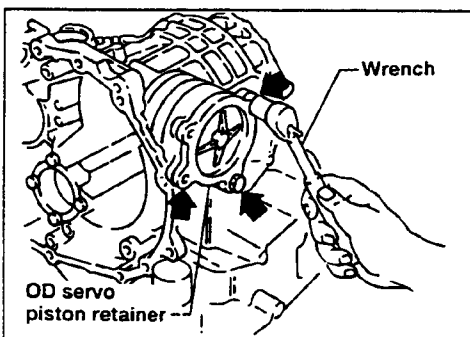

12. Tighten band servo piston fixing bolts to transmission case.

### Final Drive

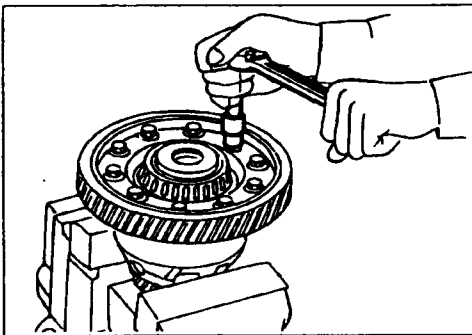
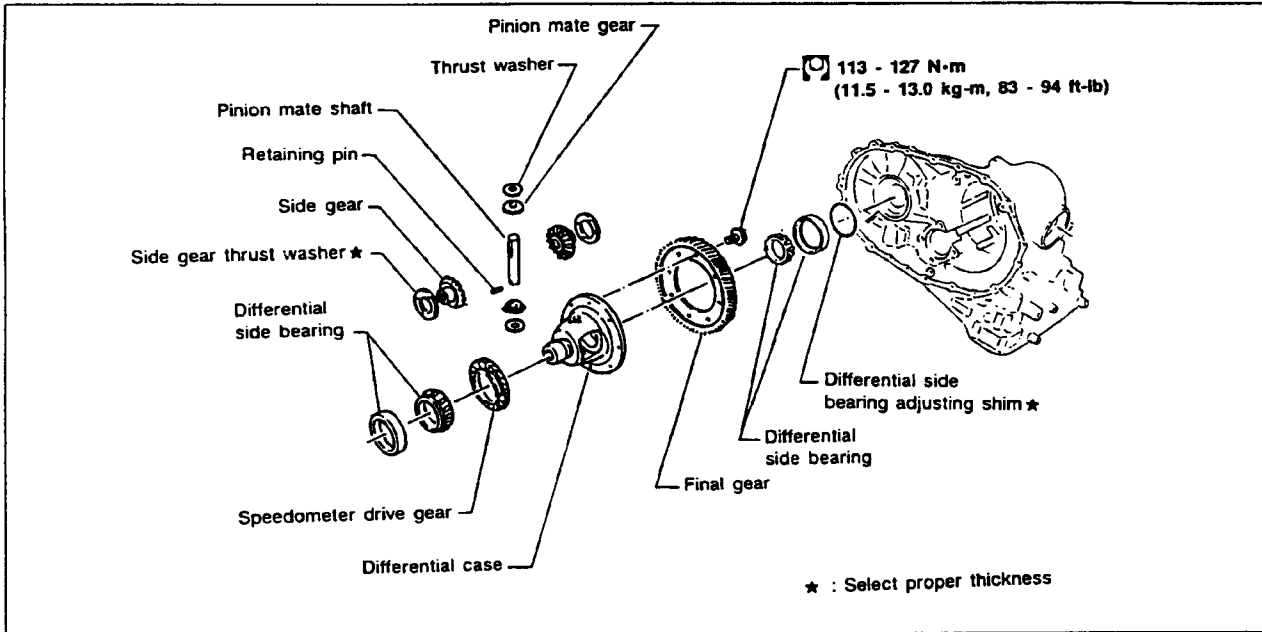

#### DISASSEMBLY

1. Remove final gear.

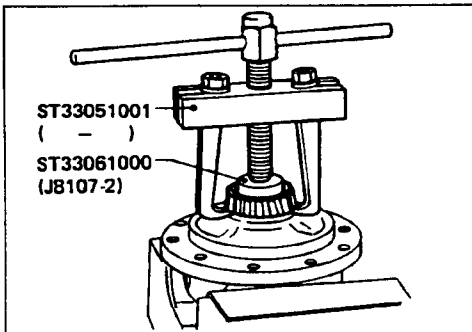

2. Press out differential side bearings.
  - Be careful not to mix up the right and left bearings.

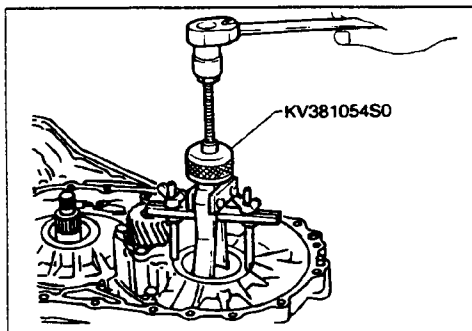

3. Remove differential side bearing outer race, and side bearing adjusting shim from transmission case.



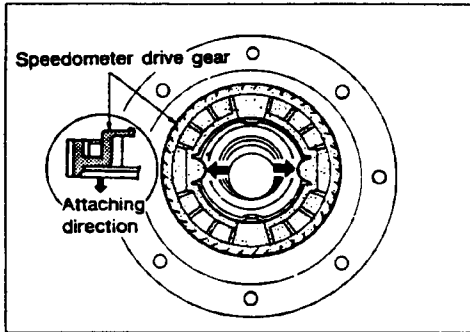

4. Remove speedometer drive gear.

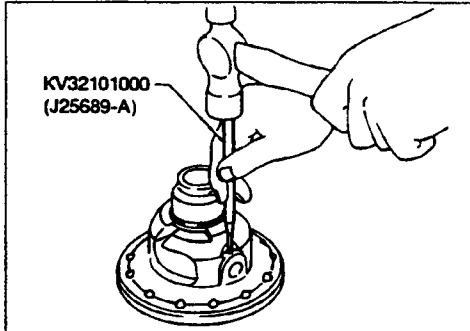

5. Drive out pinion mate shaft lock pin.

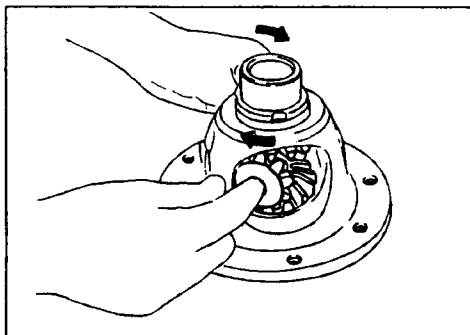

6. Draw out pinion mate shaft retaining pin.  
7. Remove pinion mate gears and side gears.

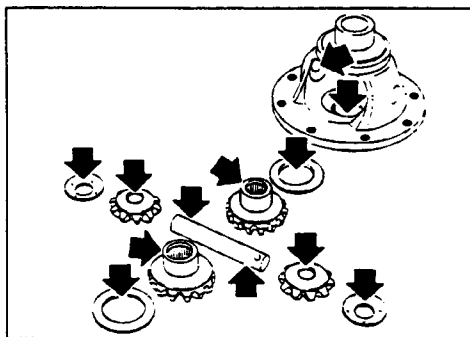

### INSPECTION

#### Gear, washer, shaft and case

- Check mating surfaces of differential case, side gears and pinion mate gears.
- Check washers for wear.

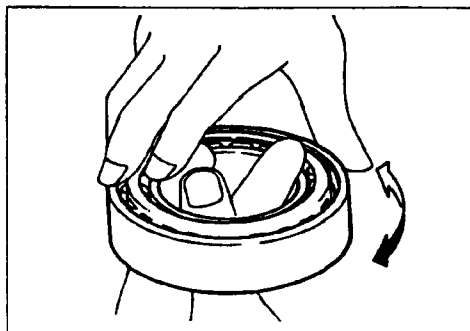

#### Bearings

- Make sure bearings roll freely and are free from noise, cracks, pitting or wear.
- When replacing taper roller bearing, replace outer and inner race as a set.

**ASSEMBLY**

1. Attach side gear thrust washers to side gears, then install pinion mate washers and pinion mate gears in place.

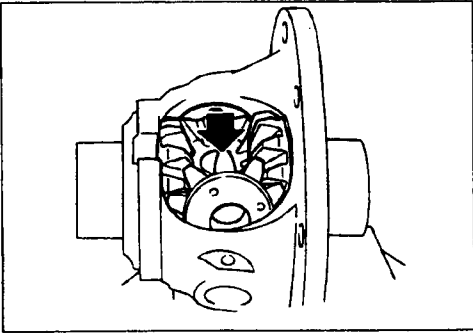

2. Insert pinion mate shaft.
  - **When inserting, be careful not to damage pinion mate thrust washers.**

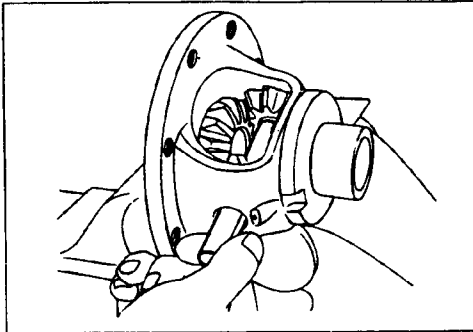

3. Measure clearance between side gear and differential case with washers following the procedure below:

- a. Set Tool and dial indicator on side gear.

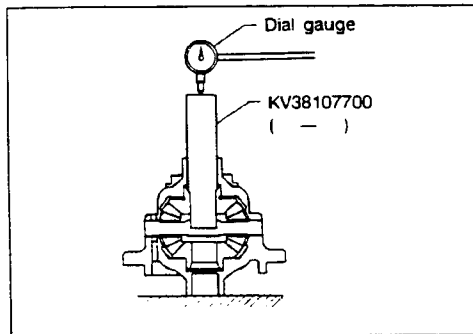

- b. Move side gear up and down to measure dial indicator deflection. Always measure indicator deflection on both side gears.  
**Clearance between side gear and differential case with washers:**  
**0.1 - 0.2 mm (0.004 - 0.008 in)**

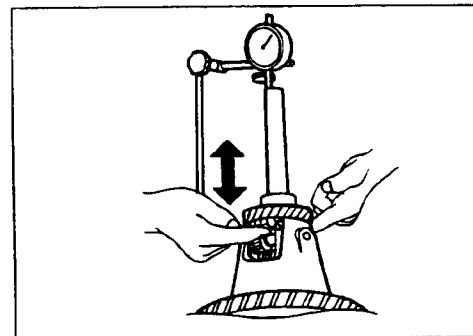

- c. If not within specification, adjust clearance by changing thickness of side gear thrust washers.  
**Side gear thrust washer:**

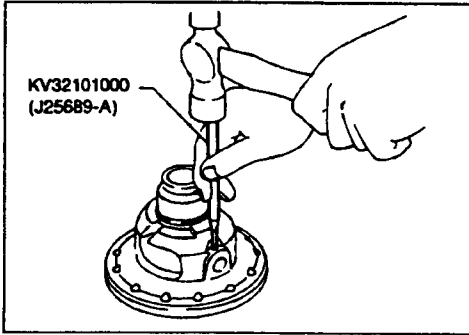

4. Install retaining pin.
  - Make sure that lock pin is flush with case.

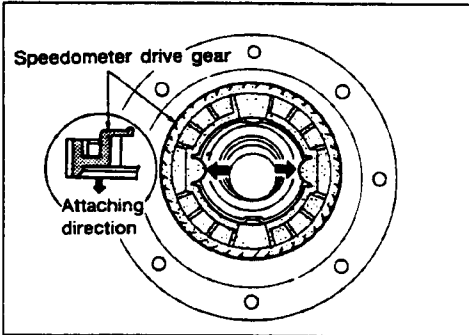

5. Install speedometer drive gear on differential case.
  - Align the projection of speedometer drive gear with the groove of differential case.

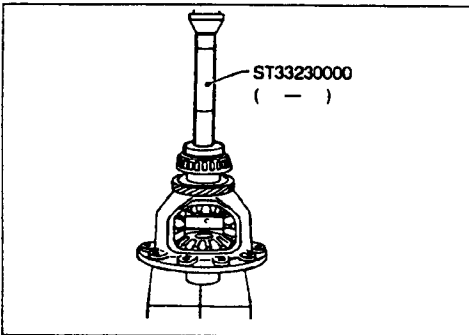

6. Press on differential side bearings.

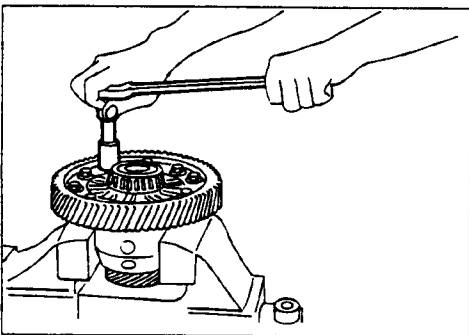

7. Install final gear and tighten fixing bolts in a crisscross pattern.

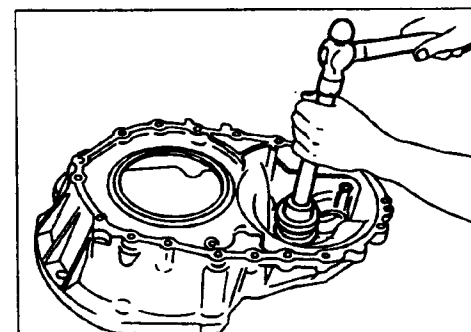
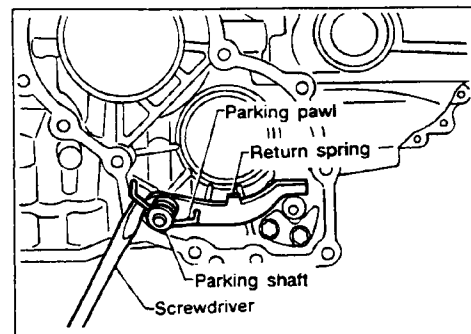
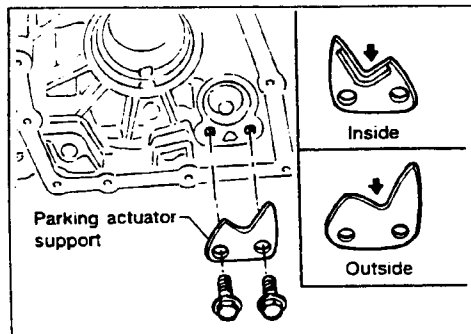
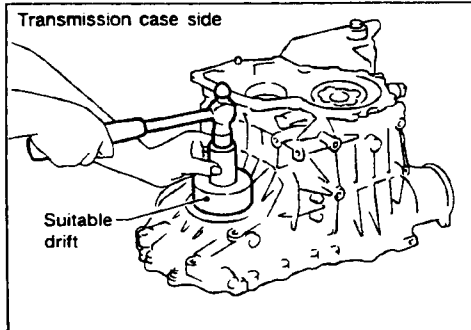
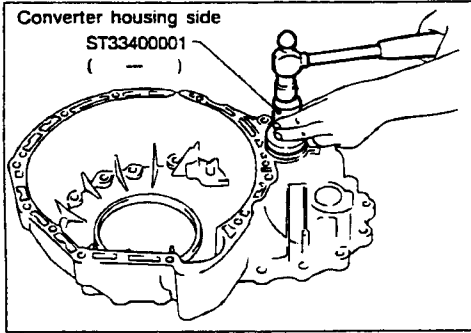

## Assembly

1. Install differential side oil seals on transmission case and converter housing.

2. Install parking actuator support to transmission case.
  - Pay attention to direction of parking actuator support.

3. Install parking pawl on transmission case and fix it with parking shaft.
4. Install return spring.

## Adjustment

### DIFFERENTIAL SIDE BEARING PRELOAD

1. Install differential side bearing outer race without adjusting shim on transmission case.
2. Install differential side bearing outer race on converter housing.

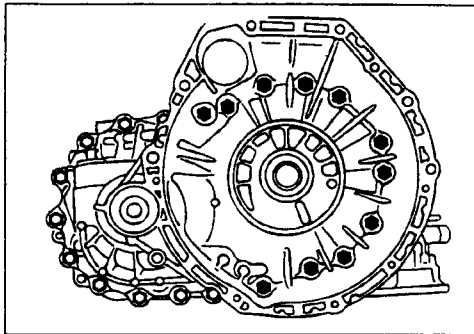

3. Place final drive assembly on transmission case.
4. Install transmission case on converter housing and tighten transmission case fixing bolts to the specified torque.

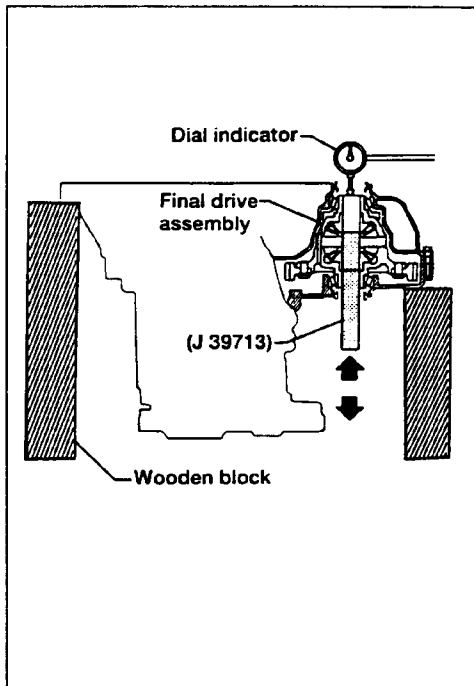

5. Attach dial indicator on differential case at converter housing side.
6. Insert Tool into differential side gear from transmission case side.
7. Move Tool up and down and measure dial indicator deflection.
8. Select proper thickness of differential side bearing adjusting shim(s).

**Suitable shim thickness = Dial indicator deflection  
+ Specified bearing preload**  
**Differential side bearing adjusting shim:**

**Bearing preload:**  
**0.05 - 0.09 mm (0.0020 - 0.0035 in)**

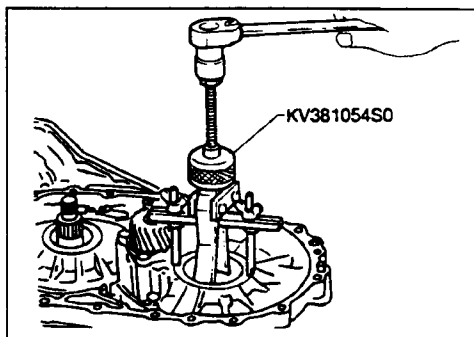

9. Remove converter housing from transmission case.
10. Remove final drive assembly from transmission case.
11. Remove differential side bearing outer race from transmission case.
12. Reinstall differential side bearing outer race and shim(s) selected from SDS table on transmission case.
13. Reinstall converter housing on transmission case and tighten transmission case fixing bolts to the specified torque.

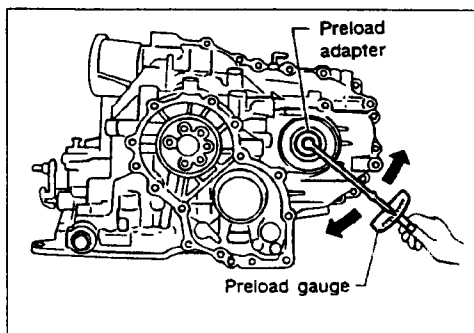

14. Insert Tool into differential side gear and measure turning torque of final drive assembly.
  - **When measuring turning torque, turn final drive assembly in both directions several times to seat bearing rollers correctly.**
  - **Turning torque of final drive assembly (New bearing):**  
 0.78 - 1.37 N·m (8.0 - 14.0 kg-cm, 6.9 - 12.2 in-lb)
  - **When old bearing is used again, turning torque will be slightly less than the above.**
  - **Make sure torque is close to the specified range.**

### REDUCTION GEAR BEARING PRELOAD

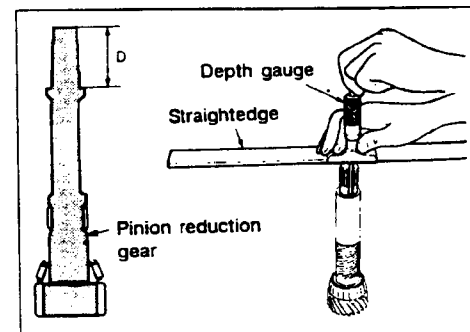
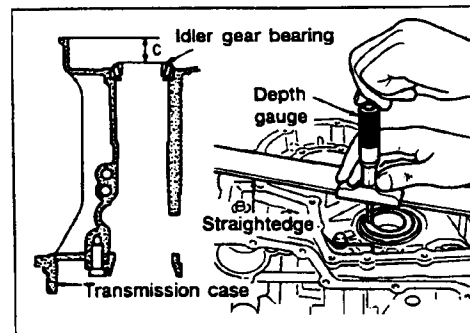
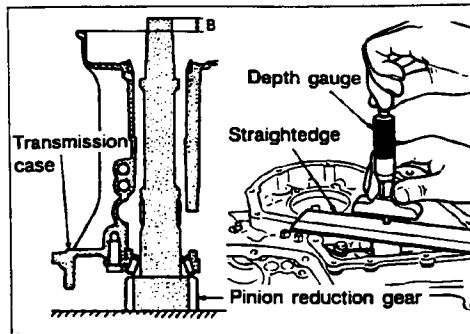
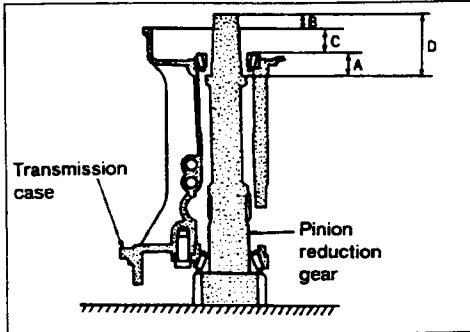
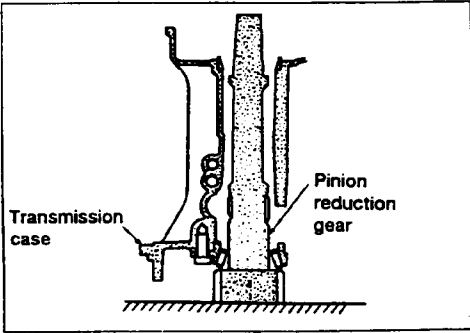

1. Remove transmission case and final drive assembly from converter housing.
2. Select proper thickness of reduction gear bearing adjusting shim using the following procedures.
  - a. Place reduction gear on transmission case as shown.

- b. Place idler gear bearing on transmission case.
  - c. Measure dimensions "B" "C" and "D" and calculate dimension "A".

$$A = D - (B + C)$$

"A": Distance between the surface of idler gear bearing inner race and the adjusting shim mating surface of reduction gear.

- Measure dimension "B" between the end of reduction gear and the surface of transmission case.
- Measure dimension "B" in at least two places.

- Measure dimension "C" between the surface of idler gear bearing inner race and the surface of transmission case.
- Measure dimension "C" in at least two places.

- Measure dimension "D" between the end of reduction gear and the adjusting shim mating surface of reduction gear.
  - Measure dimension "D" in at least two places.
  - Calculate dimension "A"
- $$A = D - (B + C)$$

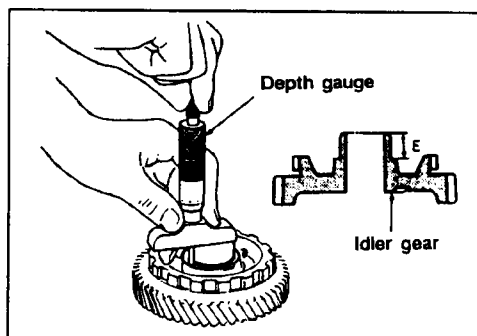

- d. Measure dimension "E" between the end of idler gear and the idler gear bearing inner race mating surface of idler gear.
  - Measure dimension "E" in at least two places.

- e. Select proper thickness of reduction gear bearing adjusting shim.

**Proper shim thickness = A – E – 0.5 mm (0.0020 in)\***

(\* ... Bearing preload)

**Reduction gear bearing adjusting shim:**

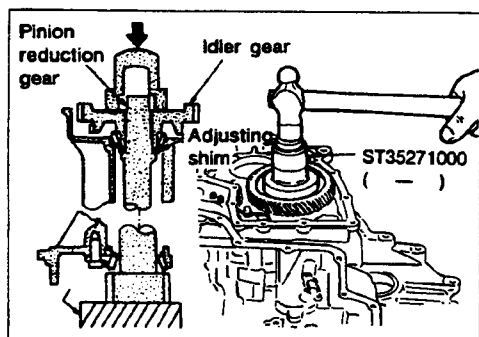

3. Install reduction gear and reduction gear bearing adjusting shim selected in step 2-e on transmission case.
4. Press idler gear bearing inner race on idler gear.
5. Press idler gear on reduction gear.
  - Press idler gear so that idler gear can be locked by parking pawl.

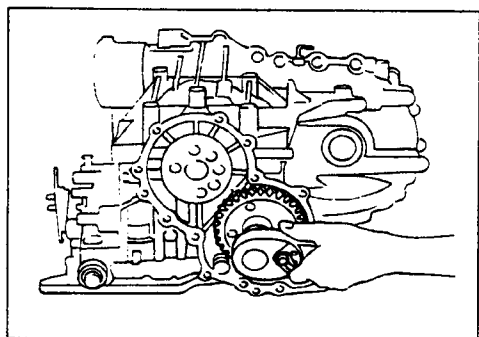

6. Tighten idler gear lock nut to the specified torque.
  - Lock idler gear with parking pawl when tightening lock nut.

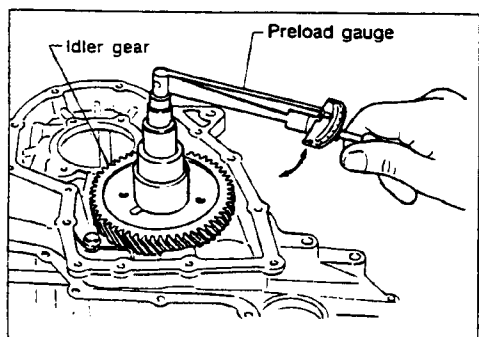

7. Measure turning torque of reduction gear.
  - When measuring turning torque, turn reduction gear in both directions several times to seat bearing rollers correctly.
 

**Turning torque of reduction gear:**  
0.049 - 0.162 N·m (0.5 - 1.65 kg-cm, 0.4 - 1.4 in-lb)
  - If turning torque is out of specification, decrease or increase thickness of reduction gear bearing adjusting shim.

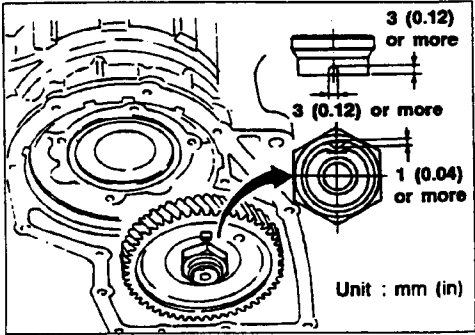

8. After properly adjusting turning torque, clinch idler gear lock nut as shown.

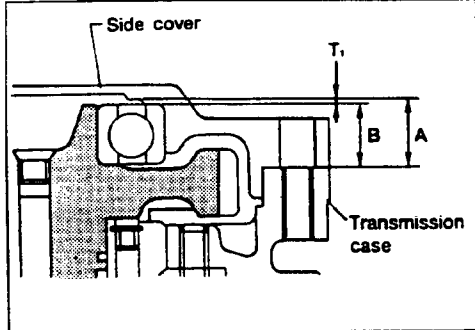

**OUTPUT SHAFT END PLAY**

- Measure clearance between side cover and the end of the output shaft bearing.
- Select proper thickness of adjusting shim so that clearance is within specifications.

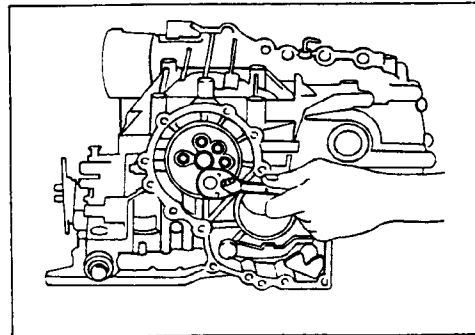

1. Install bearing retainer for output shaft.

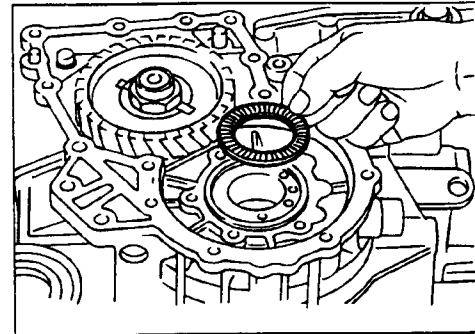

2. Install output shaft thrust needle bearing on bearing retainer.

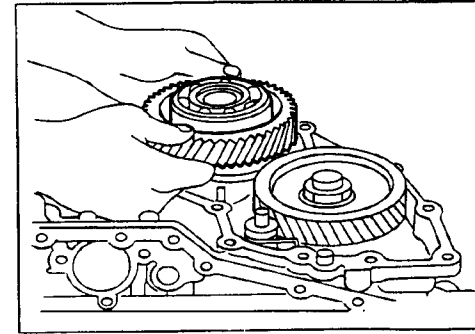

3. Install output shaft on transmission case.



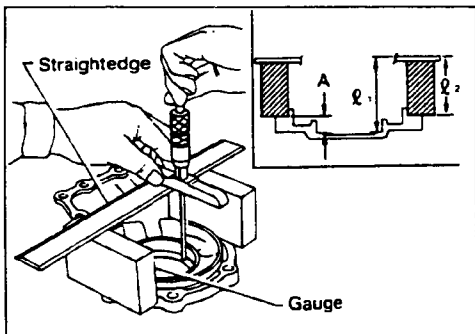

4. Measure dimensions " $l_1$ " and " $l_2$ " at side cover and then calculate dimension "A".

- Measure dimension " $l_1$ " and " $l_2$ " in at least two places.

"A": Distance between transmission case fitting surface and adjusting shim mating surface.

$$A = l_1 - l_2 \quad l_2: \text{Height of gauge}$$

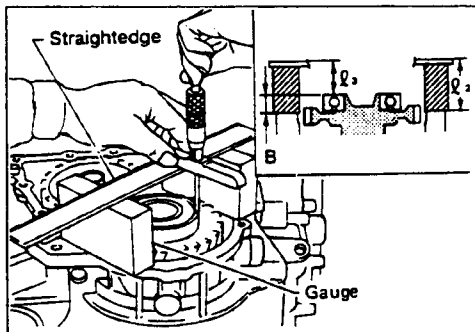

5. Measure dimensions " $l_2$ " and " $l_3$ " and then calculate dimension "B".

- Measure " $l_2$ " and " $l_3$ " in at least two places.

"B": Distance between the end of output shaft bearing outer race and the side cover fitting surface of transmission case.

$$B = l_2 - l_3 \quad l_2: \text{Height of gauge}$$

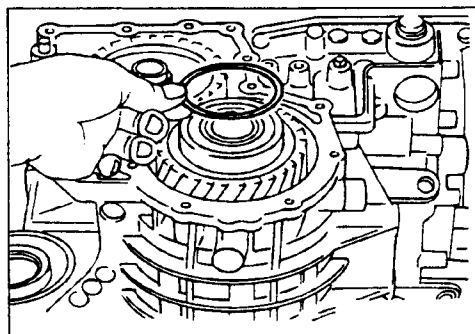

6. Select proper thickness of adjusting shim so that output shaft end play (clearance between side cover and output shaft bearing) is within specifications.

Output shaft end play (A - B):

0 - 0.15 mm (0 - 0.0059 in)

Output shaft end play adjusting shim:

7. Install adjusting shim on output shaft bearing.

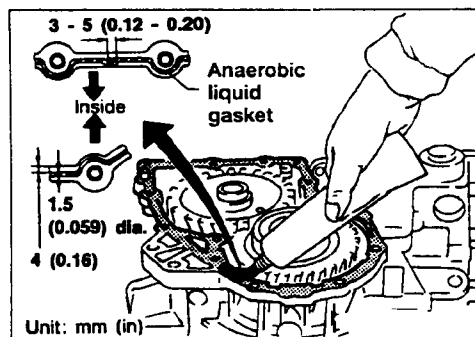

### Assembly

1. Apply anaerobic liquid gasket to transmission case as shown in illustration.

- Wash mating surfaces with a brake cleaner type solvent, allow to dry.
- The mating surfaces must be smooth (no nicks or gouges) and free of oil.
- Apply anaerobic liquid gasket Loctite P/N 51813 or equivalent to mating surface of transmission case.

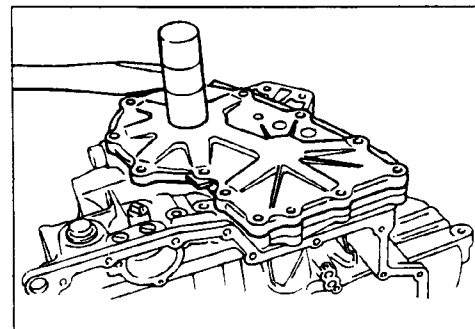

2. Set side cover on transmission case.

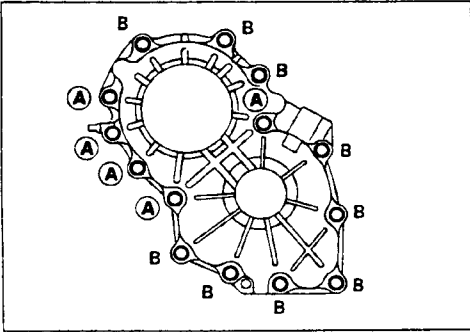

3. Tighten side cover fixing bolts to specified torque.
  - Do not mix bolts (A) and (B).
  - Always replace bolts (A) as they are self-sealing bolts.

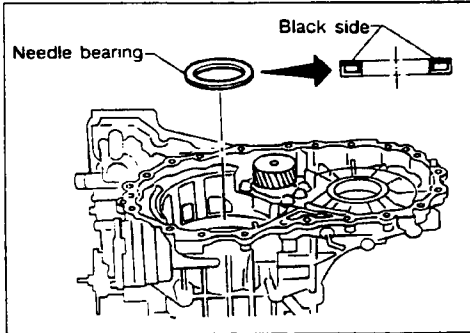

4. Remove paper rolled around bearing retainer.
5. Install thrust washer on bearing retainer.
  - Apply petroleum jelly to thrust washer.

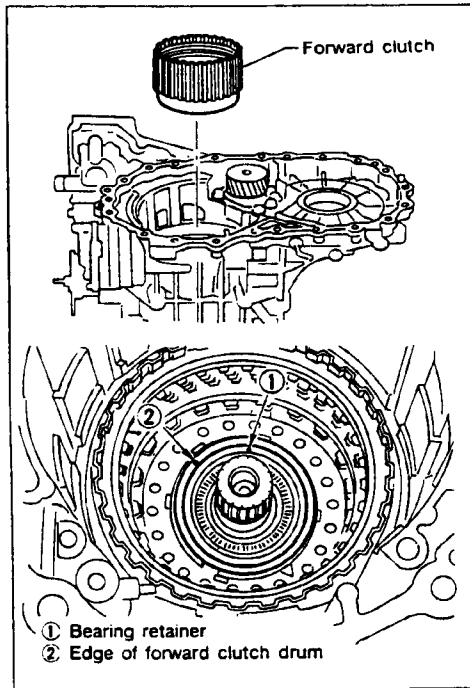

6. Install forward clutch assembly.
  - Align teeth of low & reverse brake drive plates before installing.
  - Make sure that bearing retainer seal rings are not spread.
  - If forward clutch assembly is correctly seated, points ① and ② are at almost same level.

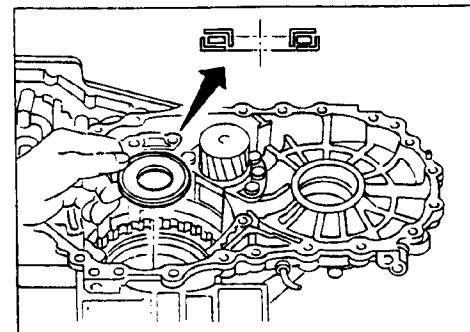

7. Install thrust needle bearing on bearing retainer.
  - Apply petroleum jelly to thrust needle bearing.
  - Pay attention to direction of thrust needle bearing.

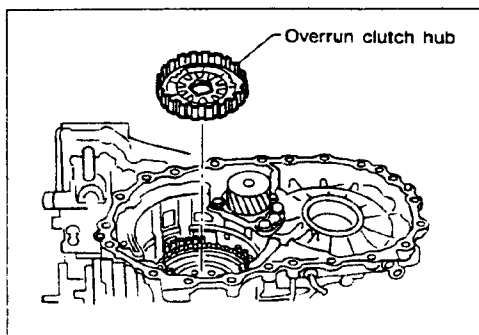

8. Install overrun clutch hub.
  - **Apply petroleum jelly to thrust washers.**
  - **Align teeth of overrun clutch drive plates before installing.**

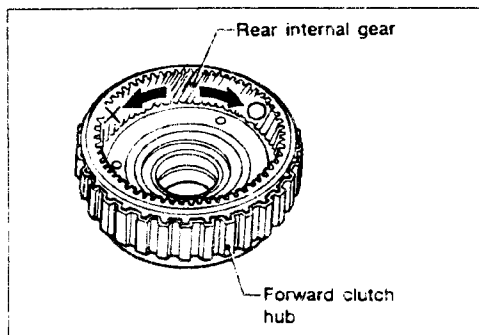

9. Hold forward clutch hub and turn rear internal gear. Check overrun clutch hub for correct directions of lock and unlock.
  - **If not shown as illustration, check installed direction of forward one-way clutch.**

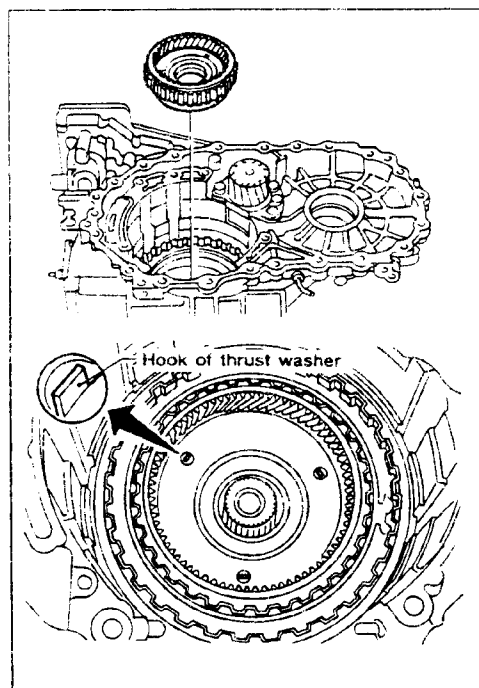

10. Install forward clutch hub and rear internal gear assembly.
  - **Align teeth of forward clutch drive plates before installing.**
  - **Check three hooks of thrust washer are correctly aligned after installing.**

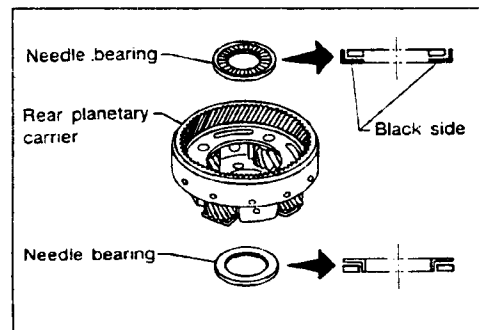

11. Install rear planetary carrier assembly and rear sun gear according to the following procedures.
  - a. Install needle bearings on rear planetary carrier.
    - **Apply petroleum jelly to needle bearings.**
    - **Pay attention to direction of needle bearings.**

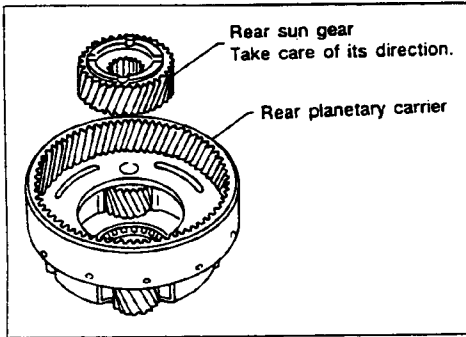

- b. Install rear sun gear on rear planetary carrier.
  - Pay attention to direction of rear sun gear.

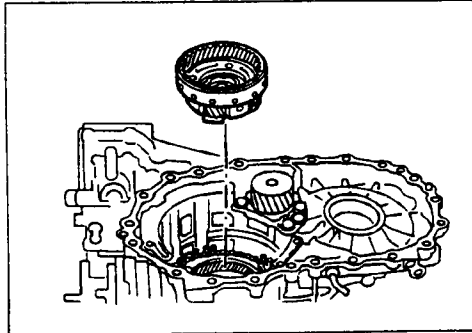

- c. Install rear planetary carrier on transmission case.

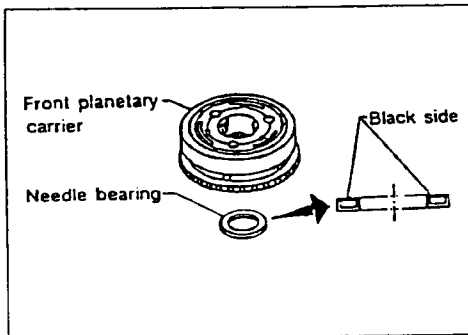

12. Install thrust needle bearing on front planetary carrier, then install them together on transmission case.
  - Apply petroleum jelly to thrust needle bearing.
  - Pay attention to direction of thrust needle bearing.

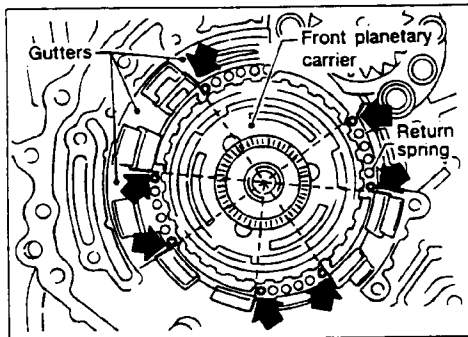

13. Install low and reverse brake piston according to the following procedures.
  - a. Set and align return springs to transmission case gutters as shown in illustration.

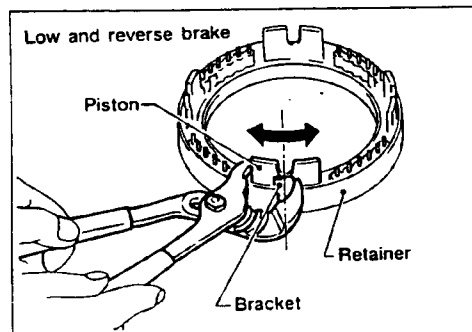

- b. Set and align piston with retainer.
  - Secure the springs to the piston with thin wire. Do not use petroleum jelly.

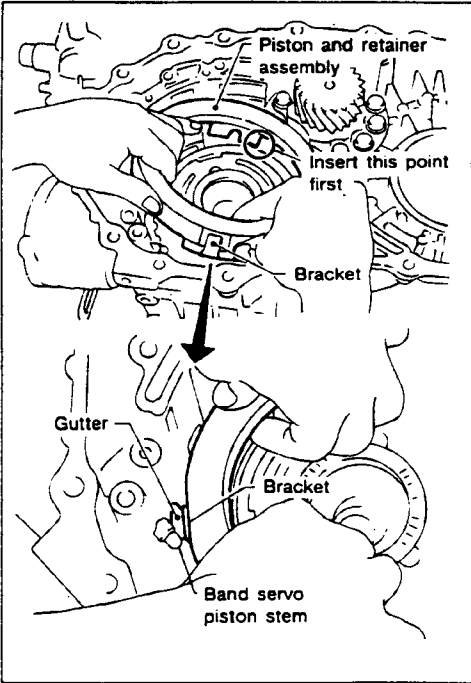

- c. Install piston and retainer assembly on the transmission case.
  - **Remove band servo.**
  - **Align bracket to specified gutter as indicated in illustration.**

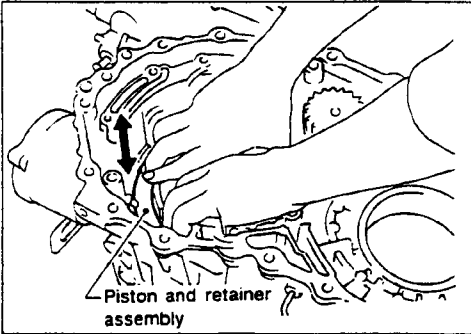

- d. Check that each protrusions of piston is correctly set to corresponding return spring as follows.  
**Push piston and retainer assembly evenly and confirm they move smoothly.**  
**If they can not move smoothly, remove piston and retainer assembly and align return spring correctly as instructed in step "a"**

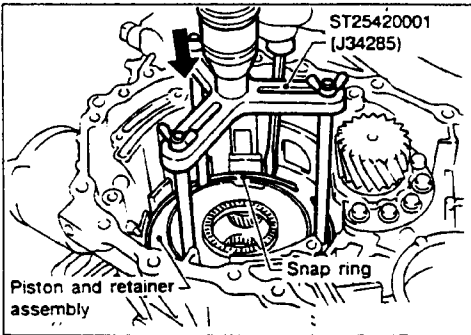

- e. Push down piston and retainer assembly and install snap ring.
- f. Install band servo.

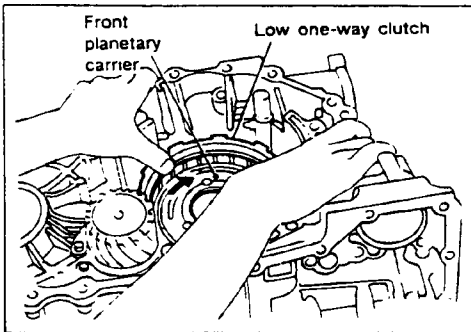

- 14. Install low one-way clutch to front planetary carrier by turning carrier in the direction of the arrow shown.

(Ridge up)

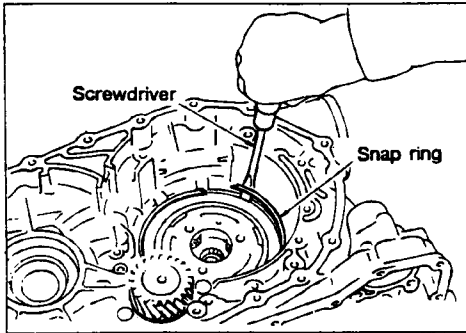

15. Install snap ring with screwdriver.

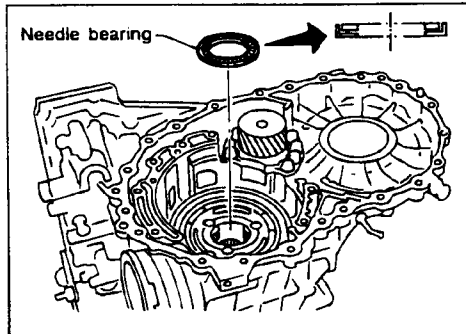

16. Install needle bearing on transmission case.

- Apply petroleum jelly to needle bearing.
- Pay attention to direction of needle bearing.

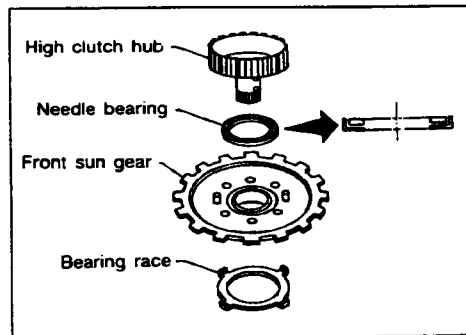

17. Install bearing race, needle bearing and high clutch hub on front sun gear.

- Apply petroleum jelly to needle bearing.
- Pay attention to direction of needle bearing.

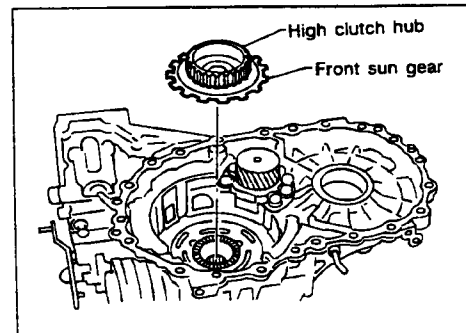

18. Install high clutch hub and front sun gear on transmission case.

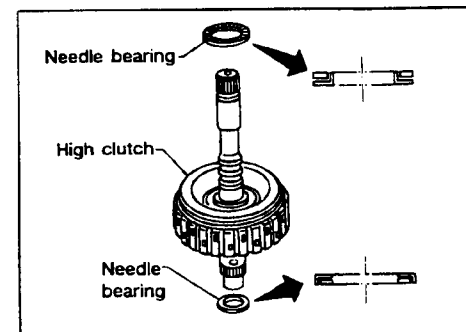

19. Install needle bearings on high clutch drum.

- Apply petroleum jelly to needle bearings.
- Pay attention to direction of needle bearings.

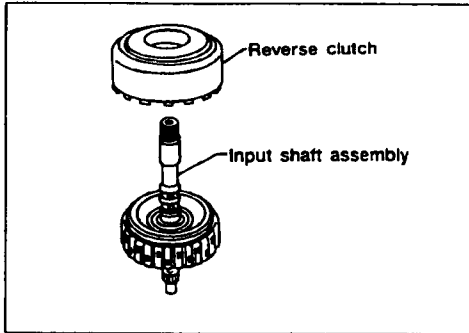

20. Remove paper rolled around input shaft.
21. Install input shaft assembly in reverse clutch.
  - **Align teeth of reverse clutch drive plates before installing.**

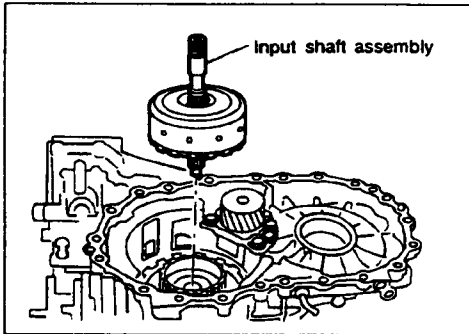

22. Install reverse clutch assembly on transmission case.
  - **Align teeth of high clutch drive plates before installing.**



## Service Information RE4FO4A

### Adjustment

When any parts listed in the following table are replaced, total end play or reverse clutch end play must be adjusted.

Part name	Total end play	Reverse clutch end play
Transmission case	•	•
Overrun clutch hub	•	•
Rear internal gear	•	•
Rear planetary carrier	•	•
Rear sun gear	•	•
Front planetary carrier	•	•
Front sun gear	•	•
High clutch hub	•	•
High clutch drum	•	•
Oil pump cover	•	•
Reverse clutch drum	•	•

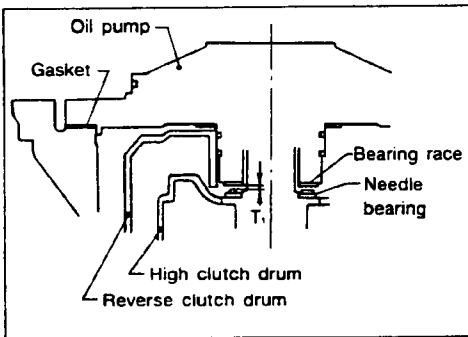

### TOTAL END PLAY

1. Adjust total end play "T<sub>1</sub>".

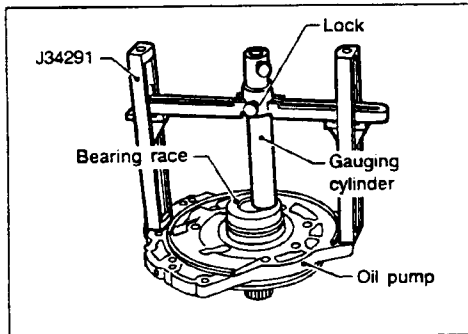

a. With original bearing race installed, place Tool onto oil pump. The long ends of legs should be placed firmly on machined surface of oil pump assembly and gauging cylinder should rest on top of bearing race. Lock gauging cylinder in place with set screw.

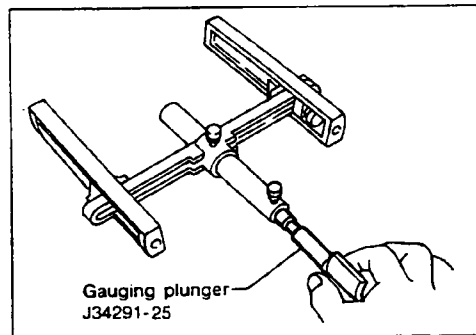

b. Install gauging plunger into cylinder.



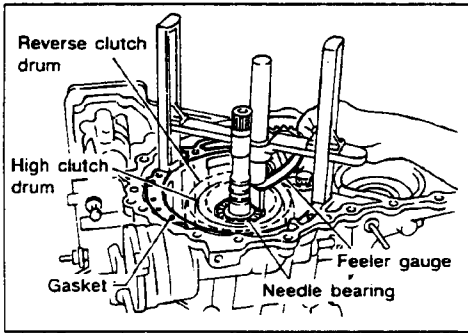

- c. With needle bearing installed on high clutch drum, place Tool legs on machined surface of transmission case (with gasket) and allow plunger to rest on needle bearing.
- d. Measure gap between cylinder and plunger. This measurement should give exact total end play.

**Total end play "T<sub>1</sub>":**

**0.25 - 0.55 mm (0.0098 - 0.0217 in)**

- If end play is out of specification, decrease or increase thickness of bearing race as necessary.

**Available bearing race:**

- 2. Adjust reverse clutch drum end play "T<sub>2</sub>".

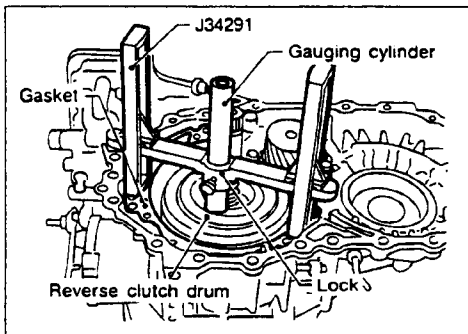
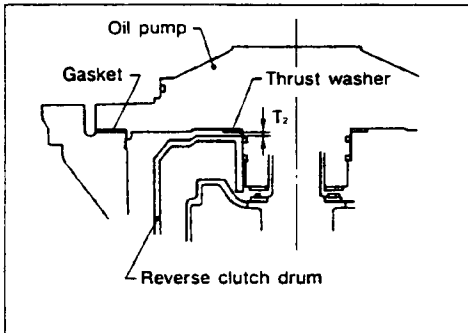

- a. Place Tool on machined surface of transmission case (with gasket) and allow gauging cylinder to rest on reverse clutch drum. Lock cylinder in place with set screw.

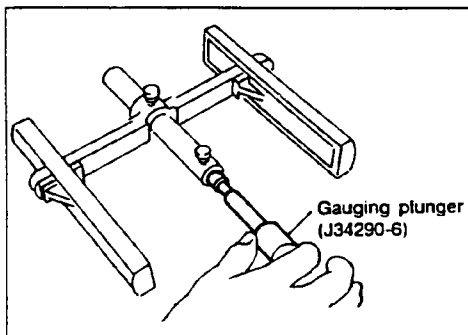

- b. Install gauging plunger into cylinder.

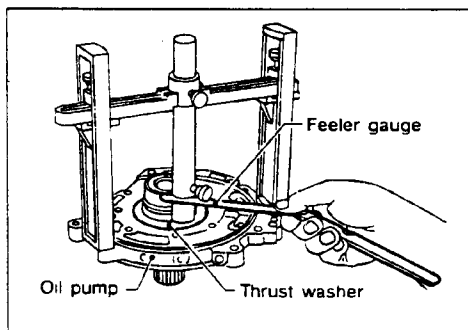

- c. With original thrust washer installed on oil pump, place Tool legs onto machined surface of oil pump assembly and allow plunger to rest on thrust washer.
- d. Measure gap between cylinder and plunger with feeler gauge. This measurement should give exact reverse clutch drum end play.

**Reverse clutch drum end play "T<sub>2</sub>":**

**0.55 - 0.90 mm (0.0217 - 0.0354 in)**

### Adjustment (Cont'd)

- If end play is out of specification, decrease or increase thickness of thrust washer as necessary.

Available thrust washer:

### Assembly

1. Install anchor end pin, washer and lock nut on transmission case.
2. Place brake band and strut on periphery of reverse clutch drum. Then, tighten anchor end pin just enough so that brake band is fitted on periphery of reverse clutch drum uniformly.

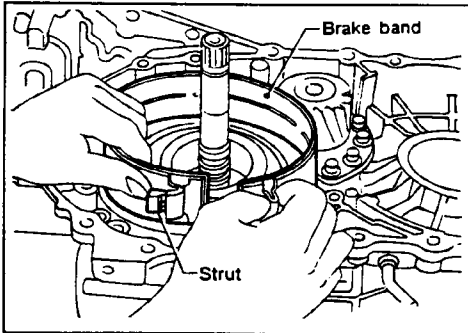

3. Place bearing race selected in total end play adjustment step on oil pump cover.
  - Apply petroleum jelly to bearing race.
4. Place thrust washer selected in reverse clutch end play step on reverse clutch drum.
  - Apply petroleum jelly to thrust washer.

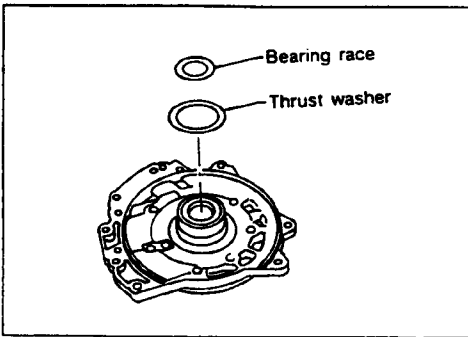

5. Install oil pump assembly, baffle plate and gasket on transmission case.
6. Tighten oil pump fixing bolts to the specified torque.

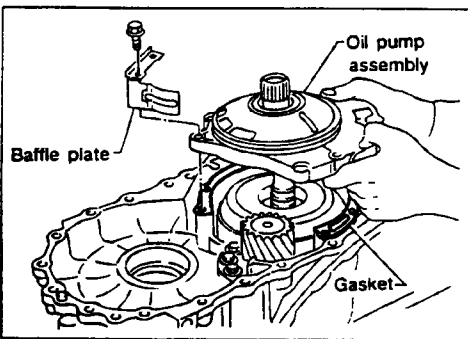

7. Install O-ring to input shaft.
  - Apply ATF to O-ring.

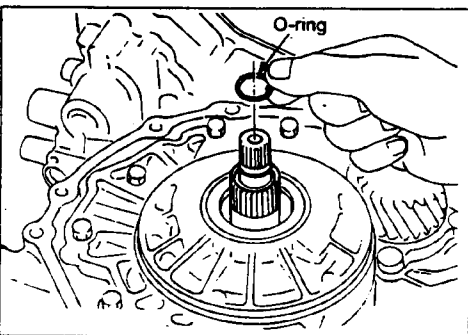

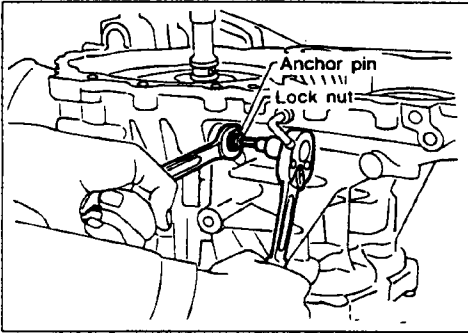

8. Adjust brake band.
  - a. Tighten anchor end pin to the specified torque.  
**Anchor end pin:**  
**⌚: 4 - 6 N·m (0.4 - 0.6 kg-m, 2.9 - 4.3 ft-lb)**
  - b. Back off anchor end pin two and a half turns.
  - c. While holding anchor end pin, tighten lock nut.

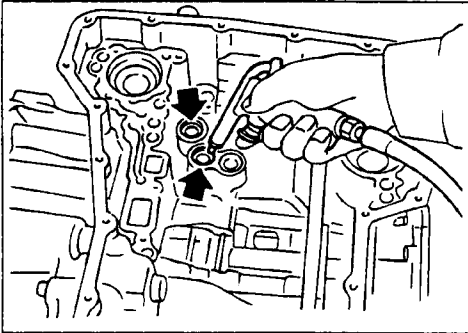

9. Apply compressed air to oil holes of transmission case and check operation of brake band.

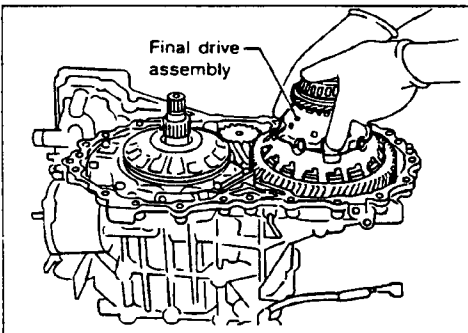

10. Install final drive assembly on transmission case.

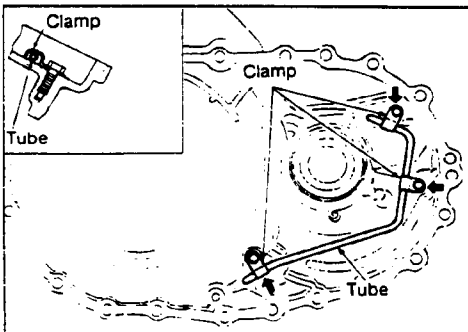

11. Install oil tube on converter housing.

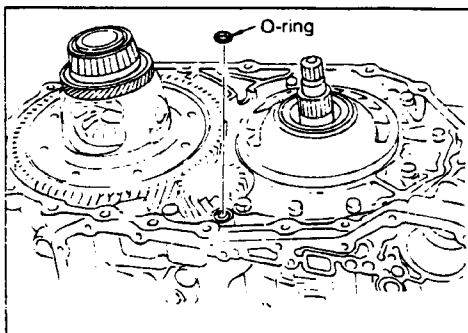

12. Install O-ring on differential oil port of transmission case.

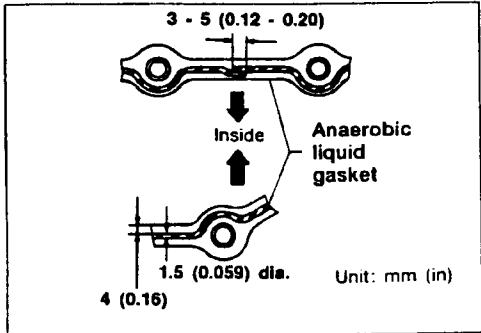

13. Install converter housing on transmission case.
- Wash mating surfaces with a brake cleaner type solvent, allow to dry.
  - The mating surfaces must be smooth (no nicks or gouges) and free of oil.
  - Apply anaerobic liquid gasket Loctite P/N 51813 or equivalent to mating surface of converter housing.

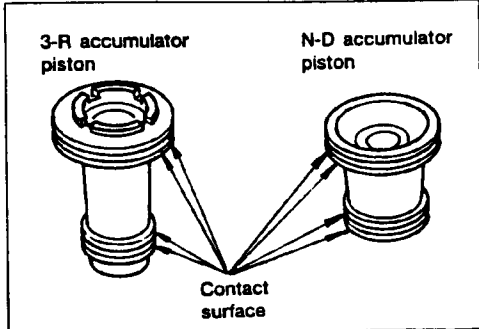
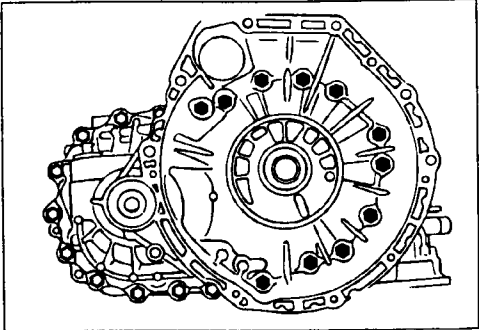

14. Install accumulator piston.
- a. Check contact surface of accumulator piston for damage.

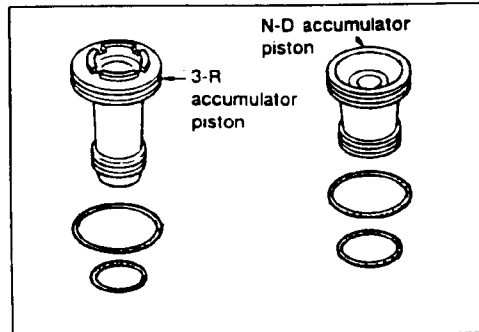

- b. Install O-rings on accumulator piston.
- Apply ATF to O-rings.

**Accumulator piston O-rings:**

Unit: mm (in)

Accumulator	Inner diameter (Small)	Inner diameter (Large)
3-R accumulator	26.9 (1.059)	44.2 (1.740)
N-D accumulator	34.6 (1.362)	39.4 (1.551)

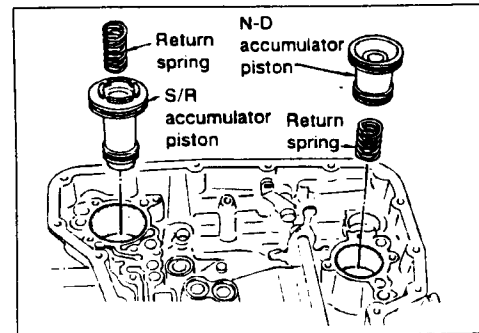

- c. Install accumulator pistons and return springs on transmission case.
- Apply ATF to inner surface of transmission case.

**Return springs:**

Unit: mm (in)

Spring	Free length	Outer diameter
3-R accumulator spring	52.5 (2.067)	20.1 (0.791)
N-D accumulator spring	43.5 (1.713)	27.0 (1.063)

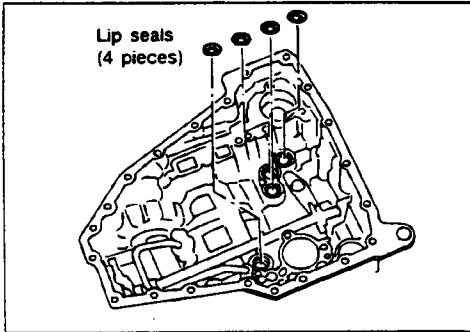

15. Install lip seals for band servo oil holes on transmission case.
- Apply petroleum jelly to lip seals.

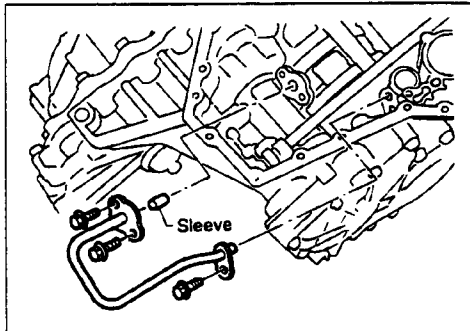

16. Install tube and sleeve.

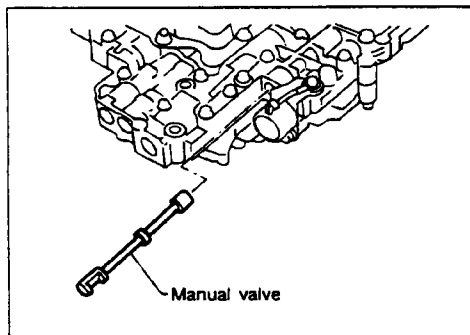

17. Install control valve assembly.
- a. Insert manual valve into control valve assembly.
- Apply ATF to manual valve.

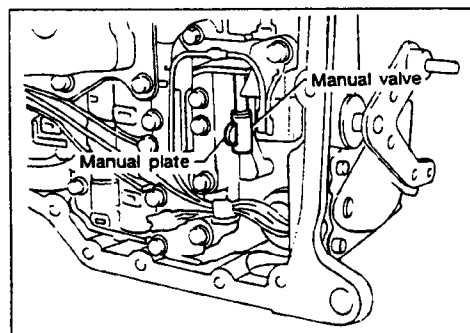

- b. Set manual shaft in Park/neutral position.
- c. Install control valve assembly on transmission case while aligning manual valve with manual plate.

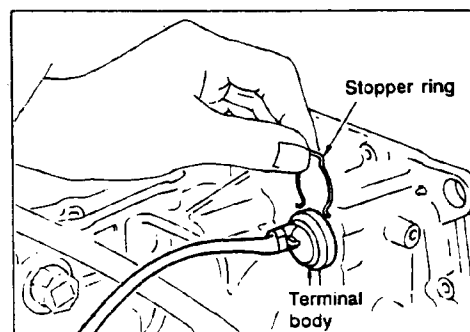

- d. Pass solenoid harness through transmission case and install terminal body on transmission case by pushing it.
- e. Install stopper ring to terminal body.

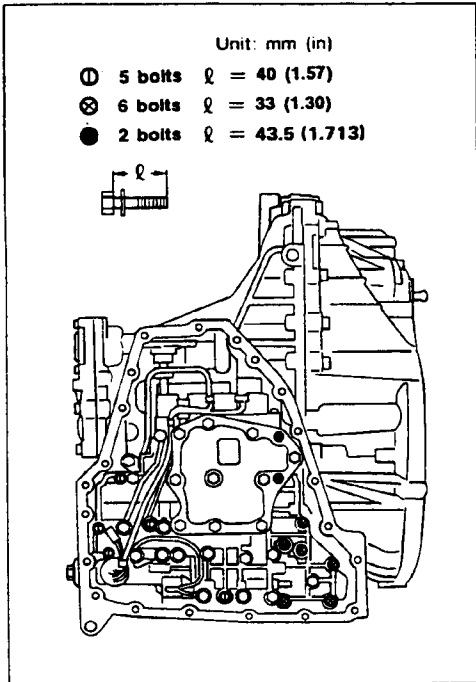

f. Tighten bolts ①, ⊗ and ●.

**Bolt length, number and location:**

Bolt	①	⊗	●
Bolt length "l"  mm (in)	40.0 (1.575)	33.0 (1.299)	43.5 (1.713)
Number of bolts	5	6	2

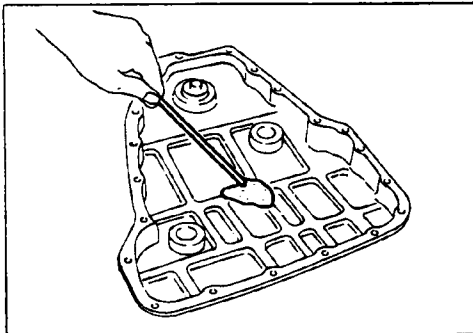

18. Install oil pan.
- a. Attach a magnet to oil pan.

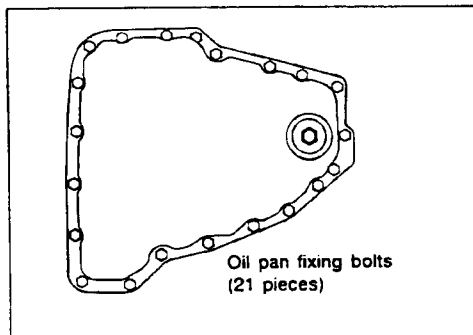

- b. Install new oil pan gasket on transmission case.
- c. Install oil pan on transmission case.
- **Always replace oil pan bolts as they are self-sealing bolts.**
- **Tighten bolts in a criss-cross pattern to prevent dislocation of gasket.**
- d. Tighten drain plug to the specified torque.

**Drain plug:**

: 29 - 39 N·m (3.0 - 4.0 kg-m, 22 - 29 ft-lb)

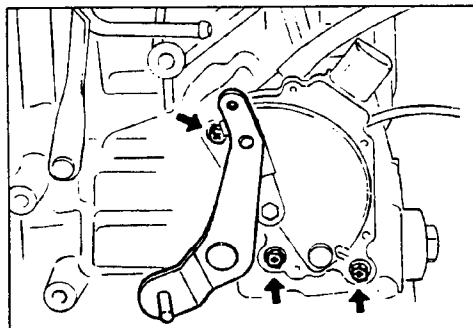

19. Install inhibitor switch.
- a. Set manual lever in "P" position.
  - b. Temporarily install inhibitor switch on manual shaft.
  - c. Move selector lever to "N" position.

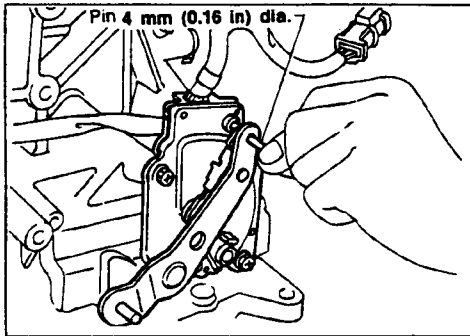

- d. Insert 4.0 mm (0.157 in) dia. pin into adjustment hole in both inhibitor switch and manual shaft as near vertically as possible.
- e. Tighten inhibitor switch fixing bolts.
- f. Remove pin from adjustment hole after adjusting inhibitor switch.

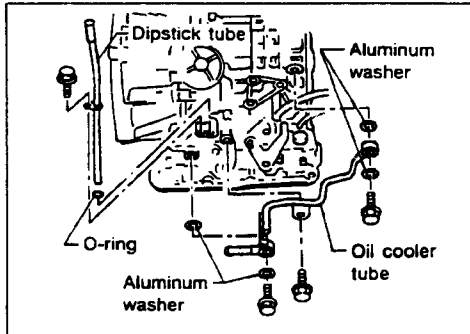

20. Install oil charging pipe and oil cooler tube to transmission case.

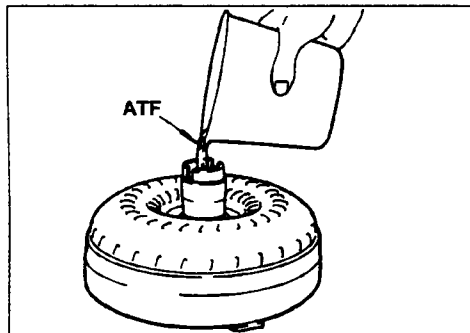

21. Install torque converter.
  - a. Pour ATF into torque converter.
    - Approximately 1 liters (1-1/8 US qt, 7/8 Imp qt) of fluid is required for a new torque converter.
    - When reusing old torque converter, add the same amount of fluid as was drained.

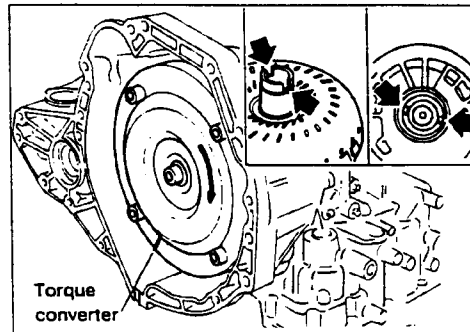

- b. Install torque converter while aligning notches of torque converter with notches of oil pump.

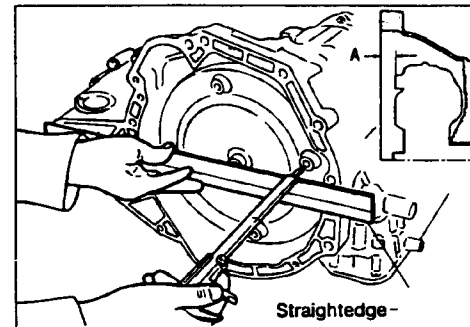

- c. Measure distance "A" to check that torque converter is in proper position.  
Distance "A": 14 mm (0.55 in) or more



## Service Information RE4FO4A

### General Specifications

Engine	VG30E
Automatic transaxle model	RE4FO4A
Automatic transaxle assembly	
Model code number	80X02
Transaxle gear ratio	
1st	2.785
2nd	1.545
3rd	1.000
4th	0.694
Reverse	2.272
Final drive	3.861
Recommended oil	Genuine NISSAN ATF or equivalent Dexron II E™ type fluid
Oil capacity ℓ (US qt, Imp qt)	8.3 (8-3/4, 7-1/4)

### Specifications and Adjustments

#### VEHICLE SPEED WHEN SHIFTING GEARS

Throttle position	Shift pattern	Vehicle speed km/h (MPH)						
		D <sub>1</sub> → D <sub>2</sub>	D <sub>2</sub> → D <sub>3</sub>	D <sub>3</sub> → D <sub>4</sub>	D <sub>4</sub> → D <sub>3</sub>	D <sub>3</sub> → D <sub>2</sub>	D <sub>2</sub> → D <sub>1</sub>	1 <sub>2</sub> → 1 <sub>1</sub>
Full throttle	Normal	52 - 60 (32 - 37)	100 - 108 (62 - 67)	164 - 174 (102 - 108)	158 - 166 (98 - 103)	90 - 98 (56 - 61)	42 - 50 (26 - 31)	42 - 50 (26 - 31)
	Power	52 - 60 (32 - 37)	100 - 108 (62 - 67)	164 - 174 (102 - 108)	158 - 166 (98 - 103)	90 - 98 (56 - 61)	42 - 50 (26 - 31)	42 - 50 (26 - 31)
Half throttle	Normal	36 - 44 (22 - 27)	63 - 71 (39 - 44)	100 - 108 (62 - 67)	65 - 73 (40 - 45)	37 - 45 (23 - 28)	8 - 16 (5 - 10)	42 - 50 (26 - 31)
	Power	37 - 45 (23 - 28)	72 - 80 (45 - 50)	117 - 125 (73 - 78)	78 - 86 (48 - 53)	41 - 49 (25 - 30)	8 - 16 (5 - 10)	42 - 50 (26 - 31)

#### VEHICLE SPEED WHEN PERFORMING LOCK-UP

Throttle opening	Gear position	Shift pattern	Vehicle speed km/h (MPH)	
			Lock-up "ON"	Lock-up "OFF"
2/8	D <sub>4</sub>	Normal	66 - 74 (41 - 46)	63 - 71 (39 - 44)
		Power	66 - 74 (41 - 46)	63 - 71 (39 - 44)
	OD OFF	Normal	86 - 94 (53 - 58)	83 - 91 (52 - 57)
		Power	86 - 94 (53 - 58)	83 - 91 (52 - 57)

#### STALL REVOLUTION

Stall revolution (rpm)	1,800 - 2,100
------------------------	---------------

#### LINE PRESSURE

Engine speed rpm	Line pressure kPa (kg/cm <sup>2</sup> , psi)	
	D, 2 and 1 ranges	R range
Idle	500 (5.1, 73)	775 (7.9, 112)
Stall	1,226 (12.5, 178)	1,961 (20.0, 284)